

INSTRUCTION MANUAL AND PARTS LIST

LATHE

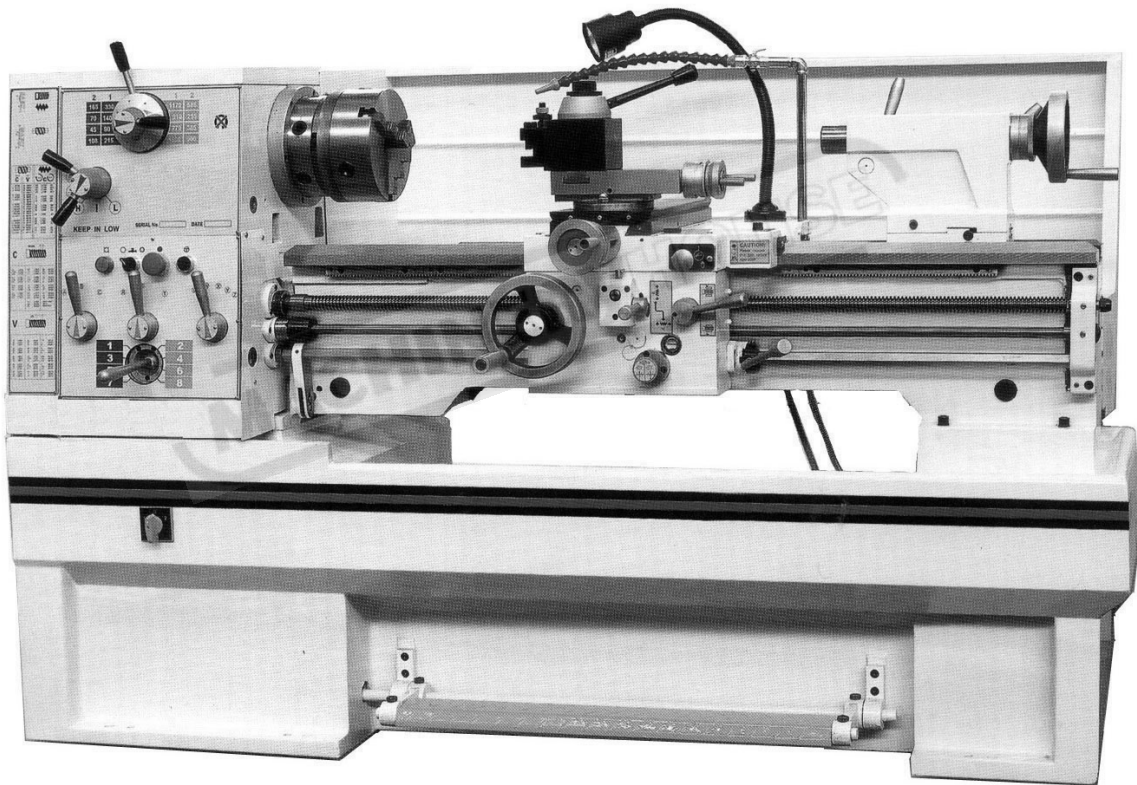

MODEL: *CD6240*

MADE IN: YANGZHOU SUPER MACHINE TOOL CO.,LTD.
ADDRESS: No.198 HEYE WEST ROAD,YANGZHOU,CHINA

CONTENTS

1. Guideline for Safety Operation	4
1-1 Safety Points for Attention	4
1-2 Danger of Operation	5
1-3 General Safe Rules for Operator of the Lathe.....	7
1-4 Protection of the Chuck	11
1-5 The Use of Emery Cloth in Metal Processing Can Cause Danger	12
1-6 Safety devices.....	14
2. Level of Noise	18
3. Specification	19
4. Lifting	20
5. Cleaning	21
6. Installing	21
7. Lathe Alignment Part.1	22
8. Lathe Alignment Part.2	23
9. Slide Ways Attention	24
10. Cross-Slide Nut	24
11. Electrical Controls	25
12. Speed Controls	26
13. Threading Dial Indicator	27
14. Chucks and Chucks Mounting	28
15. Electric Circuit Control	30
15.1 Wiring Diagram.....	30
15.2 Electric Board Diagram.....	31
15.3 Electric Listing Component.....	32
16. Bed Assembly	33
17. Change Gear	38
18. Headstock Assembly	40
19. Gear Box Control	52
20. Apron	59

21.Saddle.....	66
22.Lubrication.....	71
23.Tailstock Assembly.....	73
24.Chuck Guard Cover.....	76
25.Follow Rest.....	78
26.Steady Rest	80
27.Lead Screw Guard.....	82
28.Chip Protection.....	83



.1. Guideline for Safety Operation

The lathe is a high speed and powerful machine and can cause danger if operate it improperly.

Before operating the lathe please read the following guidelines of safety operation. Take care and observe to make the lathe be under normal operation environment so as to avoid danger.

The lathe is in accordance with GB15760-1995 <General Technical Condition of Safety Protection of Metal Cutting Machine> issued by the state.

The manual covers information and hints necessary for proper and safe operation of the lathe.

It is required the operator of the lathe should accept suitable technical training before operating the machine, own skills to operate it and hold the certificate of operation; or he should be trained under the close supervision of somebody who can skillfully operate the machine.

The lathe should be operated under the environmental temperature of +5°C - +40°C; the elevation up to 1000 m; the relative humidity of 50% when ambient temperature is +40°C or higher relative humidity if ambient temperature is lower.

The manual also covers related information for those who owns necessary skills or appointed persons to make suitable maintenance upon the machine.

1-1 Safety Points for Attention

1. Keep the lathe and the working area clean and in good order.
2. All guard devices and cover plates should be on the place; the side cover should be closed.
3. Do not place any objects in the processing area of the lathe as they may bump with rotating or moving parts.
4. Do not contact or leap over moving or rotating parts of the lathe.

5. Before starting the lathe, you should understand how to stop it.
6. The lathe cannot be operated under overload.
7. Stop running of the lathe immediately in case any accident occurs.
8. When mounting the chuck or other attachment on the spindle, switch off power supply of the lathe to prevent rotation of the spindle.
9. Do not mount the jigger if it is not checked or confirmed to be compatible with the lathe.
10. Check the center you used if its load capacity can meet with requirement.
11. Switch off power supply before leaving the lathe.
12. The maximum weight of the workpiece on the lathe is 500 kg.
13. The chuck should be properly and firmly mounted on the spindle of the lathe.
14. Take care that the workpiece should be gripped firmly and the speed of the spindle cannot exceed the safe speed of the chuck.
15. As it is possible to contact with human body, especially when the material with small diameter is used, it is not allowed in any case that the rod material cannot extend out the end of the spindle of the headstock which has no special guard and relative support.
16. There is the label of speed limit for the chuck and that no speed change is allowed in operation at the lower right corner of the headstock, the electric warning board at the electric cabinet (box) and that no touch on the workpiece (or chuck) when it is rotating on the guard of the chuck to remind you to take care.

1-2 Danger of Operation

When operating the lathe you should fully understand the danger of following operations:

1) Cutting Fluid

The cutting fluid is hazardous to human body. To contact the cutting

fluid continuously especially the original fluid, it can cause the skin allergic or ill if seriously, even the emulsion can also cause the same.

Therefore following precautions should be taken:

- a. Avoid any unnecessary contact.
- b. Put on the protective clothes.
- c. Adopt guard shield or plate.
- d. Do not wear oily or dirt clothes.
- e. Clean all parts of the body where the cutting fluid is contacted after work.
- f. Do not mix different cutting fluids.
- g. Replace the cutting fluid regularly.
- h. Correctly treat the cutting fluid.

2) Safe Operation of the Chuck of the Lathe

All jiggers of work pieces should have clear labels of the maximum safe speed and the speed of the spindle can never exceed it. It should point out that the maximum safe speed on the label is supposed under ideal work condition and lower speed of the spindle should be selected in following cases:

- a. Adopt the chuck to jig the workpiece under noisy work condition.
- b. If the chuck is surely damaged, it is dangerous to operate under high speed, especially when the chuck of grey pig iron is used it shall break if it is something damaged.
- c. If no gripping force is known before jiggling.
- d. All factors such as strength of the workpiece to be jiggled, balance of the jiggling faces and the workpiece etc. can largely affect the maximum safe speed.

When the workpiece is rotation, it may not be jiggled firmly due to the role of centrifugal force and following factors may be involved:

- a. The speed is too high.

- b. The weight and type of the claws are off standard.
- c. The working radius of the claw is unsuitable.
- d. The claw has bad lubrication.
- e. It is unbalanced.
- f. The dynamic factor is not considered in the jiggling force.
- g. Too large cutting force.
- h. Is the workpiece jiggled internally or externally?

These factors should be seriously considered as they can cause different influence in different purposes. The manufacturer cannot provide concrete data for general use as they are beyond the range controlled by the manufacturer of the machine.

1-3 General Safe Rules for Operator of the Lathe

1. When jiggling the workpiece, it cannot have oil or grease;
All parts should be jiggled firmly;
Do not intend to jig the workpiece which is unsuitable or hardly to jig well;
Do not jig the workpiece exceeding the weight allowed by the lathe;
Master suitable hoisting method when the workpiece is hoisted.
2. Ensure to remove oil or grease on handy tools and operation grippers;
Ensure the structures of handy tools and operation grippers are suitable to touch safely by hand.
3. When operating the handy tool or the operation gripper, it should be gripped firmly;
Select suitable position to grasp on the handy tool or the operation gripper;
You cannot grasp the handy tool or the operation gripper on unsuitable position;
You cannot operate with excessive force.

4. Grasp the handy tool or the operation gripper on recommended positions.

5. Do not allow to leave other handy tool or operation gripper on the chuck.

6. Do not allow to use broken, damaged or defected tool.

7. Ensure the workpiece is jigged firmly on the chuck or other jiggers.

8. Take special care of irregular workpiece.

9. Take care of large flashes and burrs on the workpiece.

10. Always take care to select correct tool in work.

11. It is not allowed to leave other unfixed handy tool or operation gripper on the chuck.

12. Do not allow to use the tool without the handle.

13. Always adopt the chuck, the follow rest and the center to support the workpiece.

14. The workpiece should have correct position in the hexagon hole and the groove of the screwdriver.

15. Take care that the locking screw should be tightened.

16. Do not make preparation work in a hurry.

17. Never use the substitute tool if no suitable tool is available or prepared in the workshop.

18. Do not allow to move away the guard plate or to open the protection door when the lathe is switched on.

19. Do not let your hands or body be within the working area of moving parts.

Take care to move parts of the lathe which could drop down.

Take care of relative position between the hand or the body and the lathe.

Take care of the tool to be grasped and other parts inserted in the chuck or the workpiece.

Do not let your hands or body be on the place where they could be hurt

by the chuck or the workpiece.

20. Take care not to push the handle, to operate the clutch or to witch on power supply to cause accident.

21. Master every function and all kinds of operation methods.

22. Never put your hands on the chuck or the workpiece to stop rotation of the spindle.

23. For the lathe driven by the clutch, in case the clutch is disengaged, the spindle should be stopped running otherwise the clutch or the brake device should be adjusted.

24. When the lathe is not in use, ensure to switch off power supply of the lathe.

25. Stop the rotation of the chuck before replacing the new workpiece.

26. Always take care to check if driving of the chuck, the belt pulley and driving parts are loose.

27. When the handle of the chuck is in the chuck, never start the spindle.

28. Do not operate the laths if the attention is not concentrated in order to avoid accident.

29. When preparing to make other operation of the lathe such as the tailstock, take care to avoid danger such as bumping or dropping.

30. Take care of guard cover of the chuck and other covers which cannot be loosened.

31. Put on the safety cap to operate the lathe if the operator has long hair to avoid danger due to hair is wounded by rotating parts of the machine.

32. Take special care to make operation if you are closing to rotating part of the machine.

33. Always pay attention to filing and deburring:

Take special care when the file or the deburring tool is closing to the chuck;

The file or the deburring tool could bump the chuck.

34. For the lathe driven by the clutch, take care that the clutch should be at the position the lathe is stopped when making measurement.

35. Take care of rotating and stopping positions of the spindle when hand is on the handle of the clutch.

36. Ensure the spindle of the lathe should be at the stop position when measuring the workpiece jigged on the chuck.

37. When the measuring meter is used on the lathe, ensure the motor is at the stop status.

38. Wear protective gears met with safe standard before making operation on the lathe;

It is not allowed if taking off protective gears in a short period of time before making operation on the lathe;

Wear protective gears properly.

39. Take care of cuttings flying out from the lathe.

40. Select suitable guard plate on the operation position.

41. Never leap over or go around the chuck or the workpiece to make adjustment when they are in running status;

Never leap over or go around the chuck or the workpiece to take something;

Take care of the place the workpiece is put when making adjustment of the lathe or the workpiece;

Never leap over or go around the chuck or the workpiece to move the tool/lathe to other position;

Never leap over or go around the chuck or the workpiece to tighten parts on the lathe;

Never leap over or go around the chuck or the workpiece to remove iron chips.

42. Master suitable method to load, and never apply force from unsuitable position.

43. Never mount the workpiece too large or heavy toward the lathe.
44. Never mount the workpiece too large or heavy toward the operator.
45. Use necessary tools to treat the workpiece.
46. Never apply excessive force on the attachment or the operation lever.
47. Take care to jig the workpiece firmly.
48. Tighten all claws, nuts, screws and fasteners.
49. Always take care to use correct equipment.
50. Never make cutting beyond the ability of the lathe.
51. Do not apply excessive force to polish or to deburr.
52. Always take care to adopt suitable tool to deburr. Do not deburr in a hurry and take care of burrs on the chuck and the workpiece.
53. Switch off power supply to stop all movements of the lathe before replacing the exchange gears.
54. Take care if the chuck/parts could drop down when the lathe is in operation.

1-4 Protection of the Chuck

The lathe is equipped with the guard of the chuck (option), which is suitable for the standard chuck.

In case the chuck guard is equipped on the lathe, it should be in a closed status before the spindle is running.

1) When the machine is equipped with larger chuck, the chuck guard should be replaced with one which has corresponding diameter with that of the chuck.

It is suggested that claws cannot extend out the outer diameter of the chuck in order to avoid bump with the chuck guard. For the sake of safe operation, always take care not to extend claws out of the outer diameter of the chuck.

2) When the face chuck is used, the chuck guard should be removed. If

it is indeed required by customer, the special chuck guard can be provided but it should be confirmed that only the face chuck is used and any case should be responsible by customer himself.

1-5 The Use of Emery Cloth in Metal Processing Can Cause Danger

In all accidents occurred on the lathe, most are from the use of emery cloth to cause breakage of fingers, or even to amputate occasionally.

When workpieces with different shapes are rotating on the lathe, if using emery cloth to deburr, to polish or to process finished sizes, it can cause the accident when winding emery cloth on the workpiece to be ground by two hands. If winding the emery cloth on the finger or to make rough grinding, the finger could be seized firmly to cause serious injury.

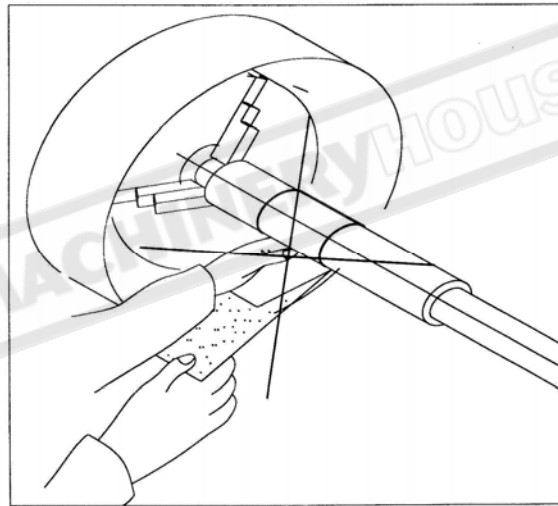

Precautions

The operator should have certain recognition and knowledge on the necessity to treat part by emery cloth on the lathe.

It is not needed to process by emery cloth in following cases:

If the requirement of the surface roughness is not so high;

Make processing by turning or on special polisher or grinding machine, the finished sizes and surface roughness can be achieved well.

If technological rule defines that the workpiece should be ground by

emery cloth, then the emery cloth should be used in following cases:

- a. Nail the emery cloth on a quality wood board to grind;

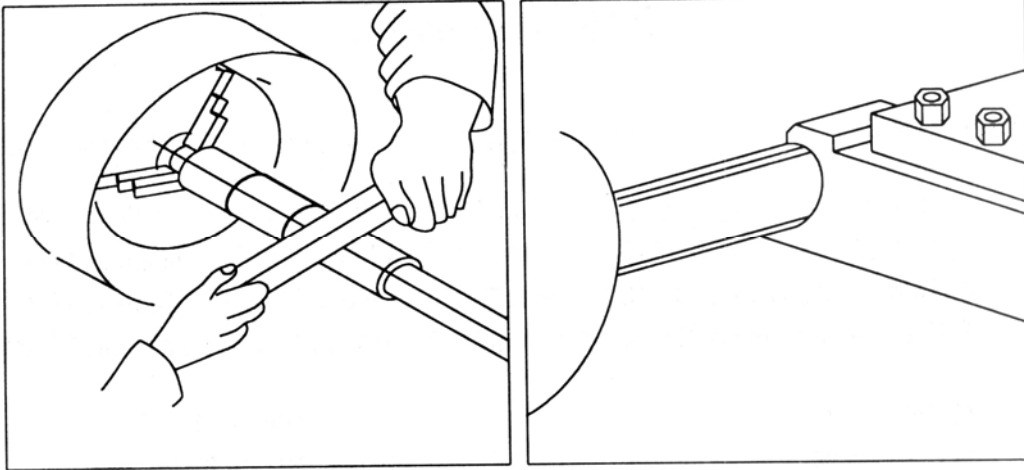

- b. The emery cloth is fixed on and jugged by the tool holder to grind.
- c. The “Robust Grinder” consists of two pieces of jointed wood board and the emery cloth to make grinding and the workpiece to be polished can go through its hole.
- d. The polish is made by the wire brush stuck with abrasive material.

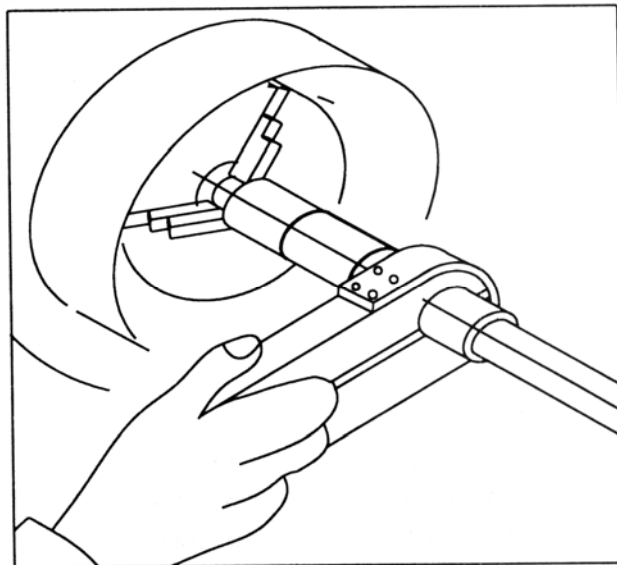

Apply force at the both ends of the emery cloth to pull it upward.
Never pull it loosely or wind it on your finger or on the workpiece.

When the end of the workpiece is polished, only a short piece of the emery cloth shall be used as it cannot be wound.

When polish by the emery cloth is made, never operate by wearing gloves.

1-6 Safety devices

Operate the lathe only with properly functioning safety devices.

Stop the lathe immediately if there is a failure in the safety device or if it is not functioning for some reason.

It is your responsibility!

If the safety device has been activated or has failed, the lathe must only be operated again when

- the cause of the failure has been removed,
- you have made sure that there is no existing danger for persons or objects.

WARNING!

If you bypass, remove or override a safety device in any other way, you are endangering yourself and other persons working on the lathe.

The possible consequences are the following

- **injuries due to components or parts of components flying off at high speed,**
- **contact with rotating parts,**
- **fatal electrocution,**
- **pulling-in of clothes.**

The lathe includes the following safety devices:

- a lockable main switch,
- an EMERGENCY-STOP button,
- a protective cover on the headstock with position switch,
- a lathe chuck protection with position switch,
- a recoil spring as protective cover on the guide spindle, the coil

spring prevents the pulling-in of clothes into the guide spindle,

- chip protection,
- securing screw
- an overload clutch on the feed shaft,
- safety screws for the Camlock bolts on the workpiece holder.

a. Lockable main switch

In the position "0", the lockable main switch can be secured against accidental or non-authorized switching-on by means of a padlock.

When the main switch is switched off, the current supply is being interrupted.

Except for the areas marked by the ideogram in the margin. In these areas, there might be voltage, even if the main switch is being switched off.



main switch

WARNING!

Dangerous voltage exists even if the main switch is switched off.

In the areas marked by the ideogram in the margin, there might be voltage, even if the main switch is switched off.

b. EMERGENCY-STOP button

The EMERGENCY-STOP button switches the lathe off.

After actuating the switch, turn it to the right, in order to restart the lathe.

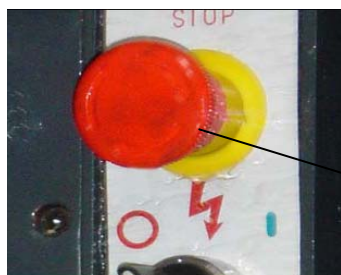

EMERGENCY-
STOP button

c. Protective cover on the headstock

The headstock of the lathe is provided with a protective cover and a position switch.

The lathe only starts when the protective cover is mounted.



positions switch

WARNING!

Only remove the protective cover when the main switch of the lathe is turned off and secured by a padlock.

d. Lathe chuck protection with position switch

The lathe is provided with a lathe chuck protection. The lathe can only be switched on if the lathe chuck protection is closed.

Lathe chuck protection

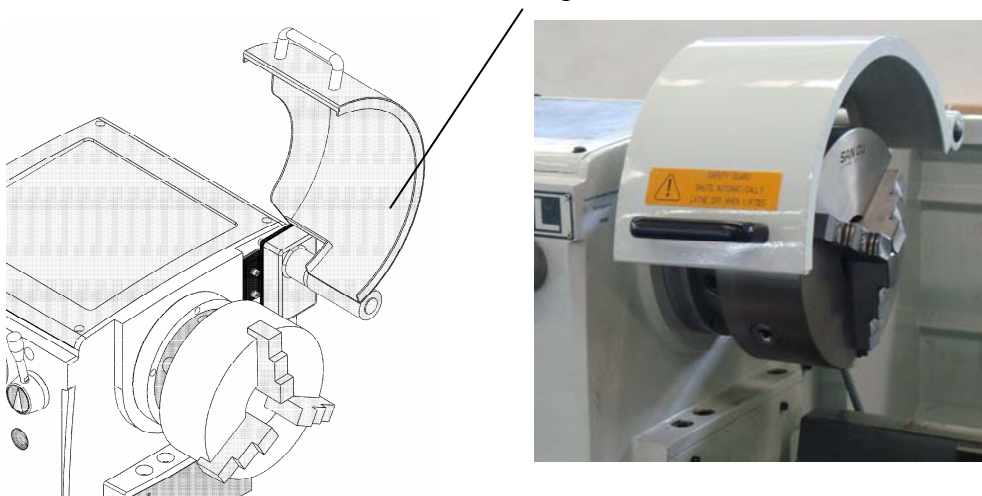

e. Chip protection

The lathe is provided with a protective cover for the tool cutting chip.

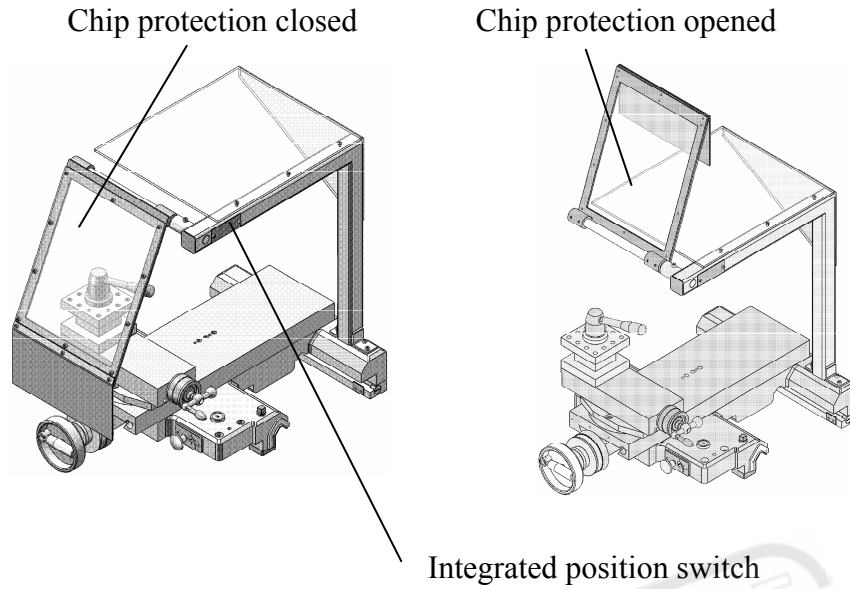

f. securing screw

Tighten the securing screw at the end of the lathe bed in order to prevent the tailstock from unintentional drawing-out of the lathe bed.

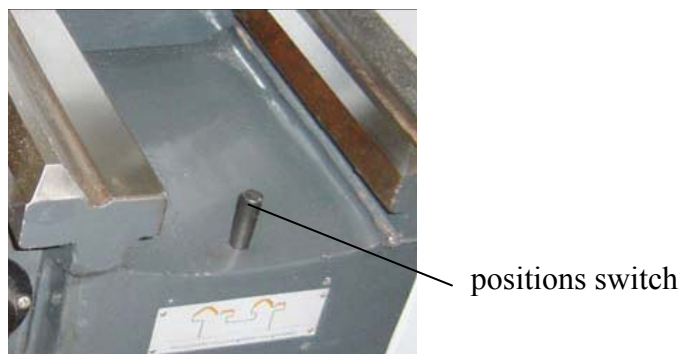

Safety check

Check the lathe at least once per shift. Inform the person responsible immediately of any damage, defect or change in the operating function.

Check all safety devices

- at the beginning of each shift (with the machine stopped),
- once a week (with the machine in operation),
- after every maintenance and repair work.

Check that the prohibition, warning and information labels as well as the markings on the lathe

- are legible (clean them, if necessary),
- are complete.

2. Level of Noise

According to GB/T16769-1997 <Measurement Method of Sound-Pressure-Level of Metal Cutting Machine>, measure the noise at six positions being one meter far from the lathe. The maximum noise should be less than 85dB (A) .

Note: The measurement should be made at the spindle with standard chuck at the maximum speed.

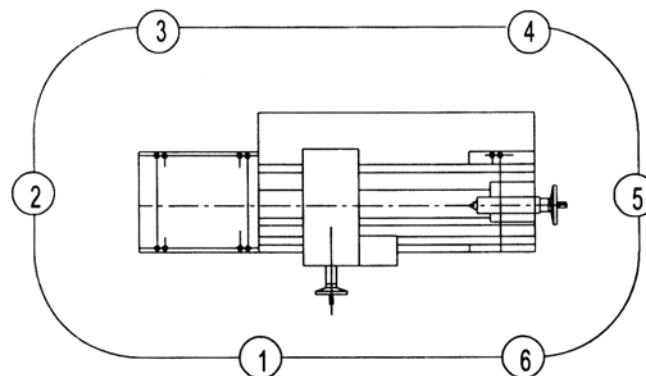

3. Specification

Capacity

Swing Over Bed	360mm(14") or 410mm(16")
Swing Over Cross Slide	215mm(8 1/2") or 255mm(10")
Swing In Gap Diameter×Width	540(21 1/4") or 580(23")×190(7 1/2")
Height of Center	185mm(7 1/2") or 205mm(8")
Distance Between Centers	1000mm(40")/1500 mm
Width of Bed	250mm(10")
Cutting Tool Max Section	20×20mm(3/4"×3/4")
Total Travel of Cross Slide	210mm(8 1/2")
Total Travel of Top Slide	140mm(5 1/2")

Headstock

Spindle Bore	52mm(2")
Spindle Nose	D1-6
Spindle Morse Taper in Bore	M.T.No. 6
Spindle Speeds Number	16
Spindle Speeds Range	45-1800R.P.M

Thread & Feeds

Leadscrew Diameter & Thread	28mm×6mm or 4T.P.I
Threads Imperial Pitches	2-72T.P.I(45Nos)
Threads Metric Pitches	0.2-14mm(39Nos)
Longitudinal Feeds Imperial	0.002"-0.067"/Rev (17Nos)
Longitudinal Feeds Metric	0.05-1.7mm/Rev (17Nos)
Cross Feeds Imperial	0.001"-0.0335"/Rev (17Nos)
Cross Feeds Metric	0.025-0.85mm/Rev (17Nos)
Range of Module Pitches	0.3-3.5MP(18Nos)
Range of Diametral Pitches	8-44DP(21Nos)

Tailstock

Total Travel of Tailstock Quill	120mm(4 3/4")
Tailstock Quill Diameter	50mm(2")
Taper in Tailstock Quill	M.T.No.4

Motors

Spindle Drive Motor	4P/8P, 3PH 3.3/2.2kw or 4.5/3kw
Coolant Pump Motor	4P, 3PH 90W

Weight & Measures

Machine Space Requires (L×W×H)	194 (244) cm×85cm×130cm or 132cm
Packing Case Dimensions (L×W×H)	206 (81")×90 (35 ⁷ / ₁₆ ")×164cm(64 ⁹ / ₁₆ ")
Net Weight	1300kg or 1350kg/1550kg or 1600kg
Gross Weight	1500kg or 1555kg/1750kg or 1755kg

4. Lifting

Use a sling-chain to sling the lathe as in fig position the saddle and tailstock along the bed to obtain balance.

Important: The sling-chain should not touch the leadscrew or Feed-shaft to avoid damage.

Unloading of the machine. When the machine is unloaded from the car or to be moved, please proceed with following steps (Fig.1)

1. Preparing two round sticks (long approx.800mm dia 35mm) insert into the preserved holes on lathe bed. Then lift up with applying wires on both end of the stick.

Lifting the machine by a crane.

3. Before lifting adjust the position of Lathe Apron and Tailstock to maintain the balance of machine.

4. When the machine was shifted to its destination, always handle with care to put it down. Don't let go of it to hit the ground or it will affect the accuracy of the machine

Note: Machine weight can be seen in Specification Table.

5. For the adjustment of electric control, keep the distance between machines and wall not less than 600mm.

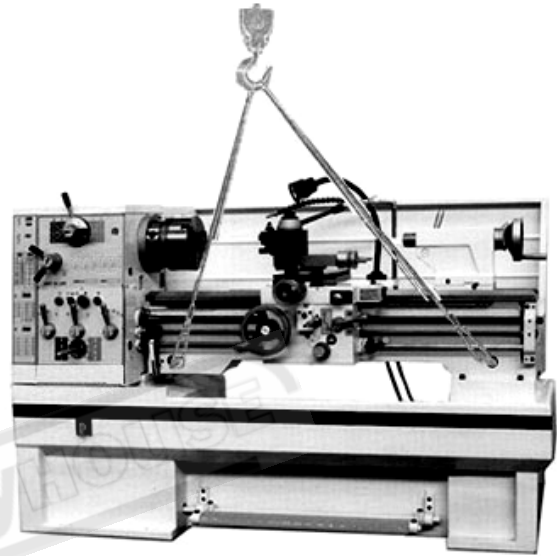

Fig.1

5. Cleaning

Before operating any controls remove the anticorrosion coating from all slideways and the end gear train, using white spirit or kerosene.

Do not use cellulose solvents for cleaning, as they will damage the paint finish.

Oil all bright-machined surfaces immediately after cleaning using machine oil or slide way lubricant; use heavy oil or grease on the end gear.

6. Installing

Locate the machine on a solid foundation, allowing sufficient area all around for easy working and maintenance (see Foundation plan). The lathe may be used freestanding or bolted to the foundation.

Freestanding: Position lathe on foundation and adjust each of the six mounting feet to take equal share of the load. Then using an engineer's precision level on the bedways (Fig.2) adjusts the feet to level up machine. Periodically check bed level to ensure continued lathe accuracy.

Fixed installation: Position lathe over six bolts (1/2 in. or 12mm.dia.) set into the foundation to correspond with holes in the mounting feet; Accurately level the machine, then tighten hold-down bolts, Re-check bed level.

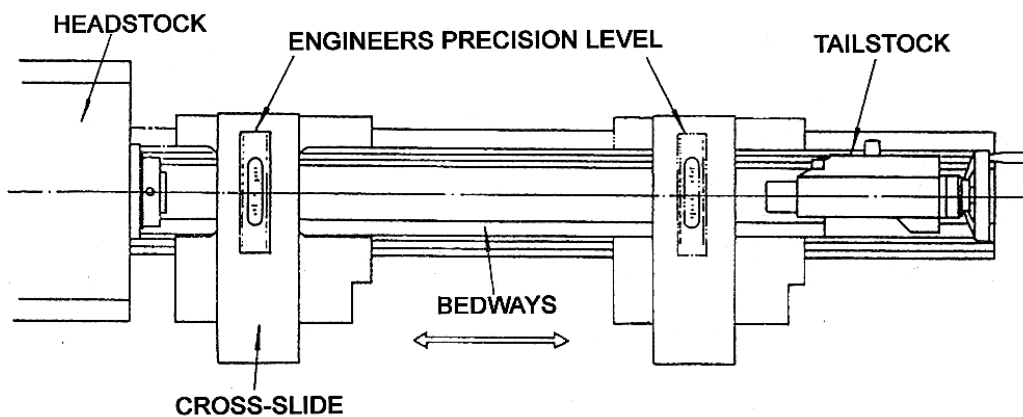

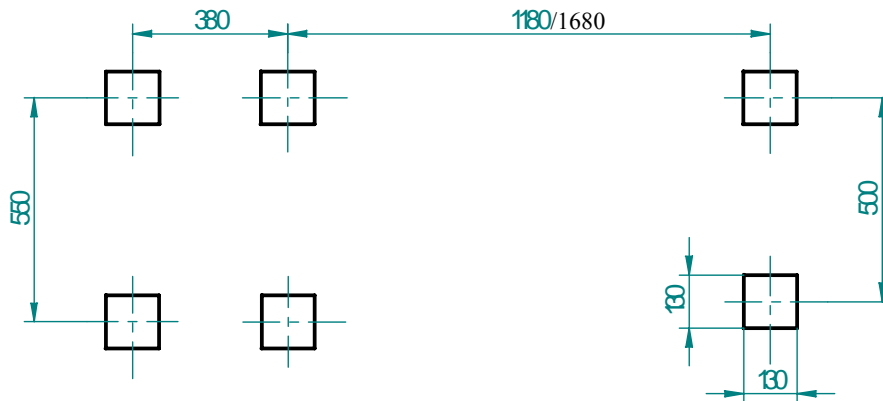

Fig.2

Construction of the Ground

Due to the recent tendency of utilizing Ultra-Hard Alloy Steel tools, it surely increases the speed of heavy cutting comparing to the previous steel tool. But, in the mean time, it easily happens to the vibration of the machine. For assuring better cutting result, it requires a very strong and steady construction of ground. (Please refer to right illustration of construct in of ground)(Fig.3)

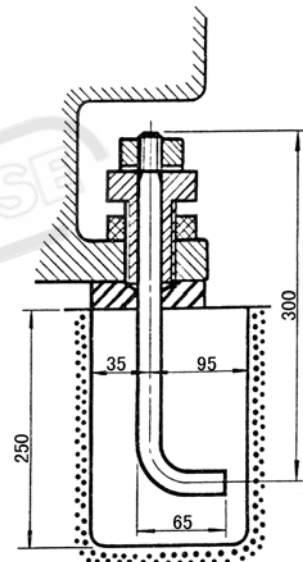

Fig.3

7. Lathe Alignment Part.1

With the lathe install and running. We recommend a check on machine alignment before commencing work. Check leveling and machine alignment at regular periods to periods to ensure continued lathe accuracy.

Headstock check: Take a light cut-with a keen tool over a 6 in. (150mm.) length of 2 in. dia. (50mm) steel bar gripped in the chuck but

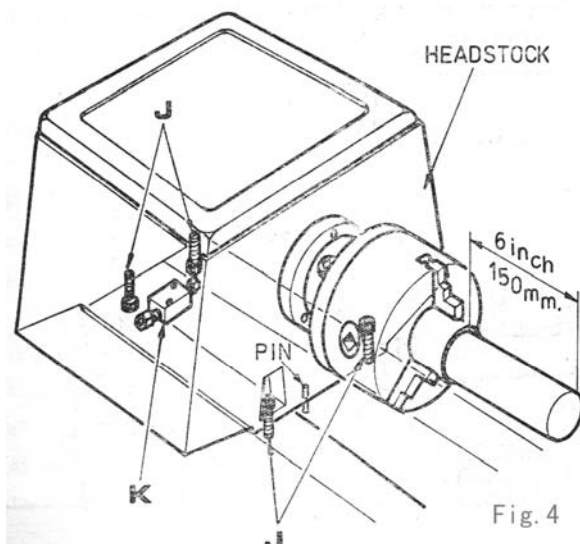

Fig.4

not supported at the free end. Micrometer reading at each end of the turned length (at A and B of Fig.4) should be the same.

To correct a difference in readings, slacken and release the four-headstock hold-down screws (J) shown in Fig.4 and adjust the set-over screw (K) beneath the headstock. Then tighten all screws, after adjustment and repeat the test-cut/micrometer-reading sequence until micrometer readings are identical, so machine now cutting absolutely parallel.

The Importance and Methods of Spindle Leveling Adjustment

1. Switch on to make the Spindle turn while the Spindle is set up at 1170r.p.m. By putting the palm of the left hand on the Headstock cover to feel its chatter. An unrevealing Spindle will lead to lathe chatter. Move Leveling Block (either “A” or “B”) left or right to adjust until your left hand feels the minimum chatter.

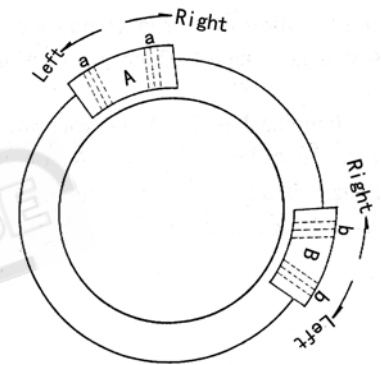

Fig.5

2. Afterwards, change the Spindle speed to 1800r.p.m. or 770r.p.m. and check the Leveling with the same way as we did at 770r.p.m. by adjusting the Leveling Block “A” or “B”.

8. Lathe Alignment Part.2

Using a 12in. (305mm.) ground steel bar fitted between headstock and tailstock centers, check the alignment by fitting a dial-test indicator to the topside and traversing the center line of the bar. (Fig.6).

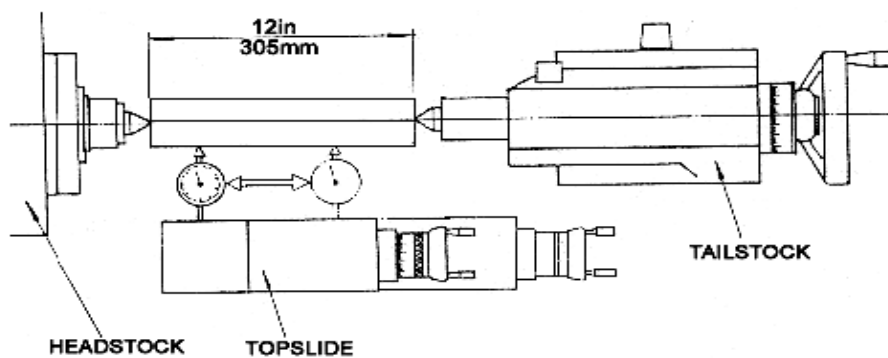

Fig.6

9. Slide Ways Attention

Tapered gib strips are fitted to slideways of saddle cross-slide and top (compound) slides so that any slackness, which may develop can be rectified.

Ensure that slideways are thoroughly cleaned and lubricated before attempting adjustment. Then reset the gib screw and tightening the front screw, a little at a time. Check constantly for smooth action throughout full slide travel; avoid over adjustment which can result in increased wear-rate are stiff or jerky action. (Fig.8)

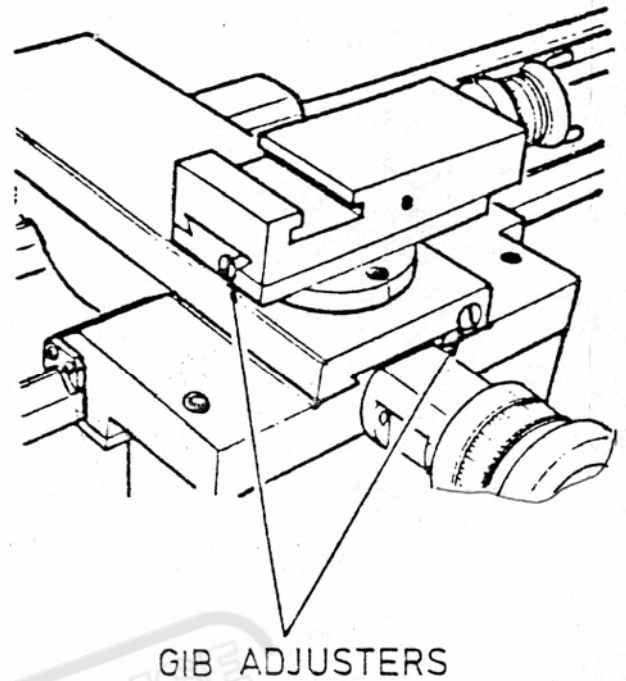

Fig.8

10. Cross-Slide Nut

This is adjustable for elimination of slackness, which may develop in service. Reduce backlash by the cap-head screw rear of the nut. Before operating the cross-slide several times by hand to be sure of smooth operation throughout travel. (Fig.9)

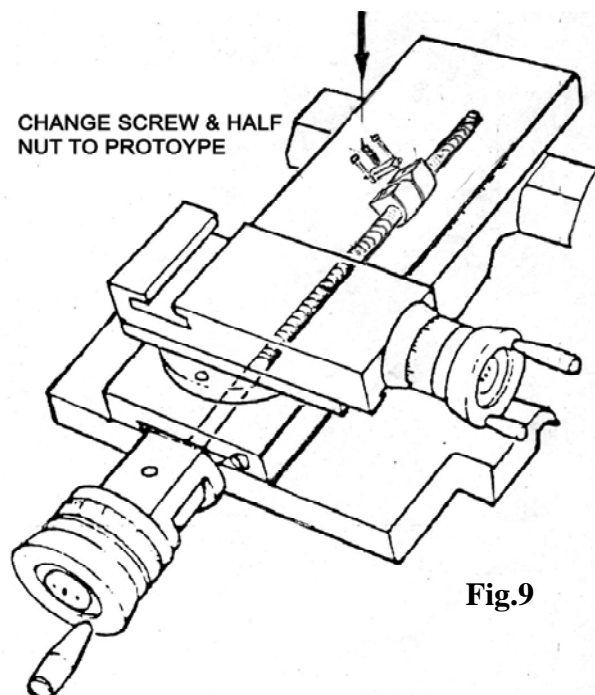

Fig.9

11. Electrical Controls

The power switches are fitted on the face of electrical box in back of the bed and below the headstock. Except the main switch, all electrical controls are fitted in the front of the headstock.

1. Move the power switch set at ON position then the indicator lamp glows.

2. Press the GREEN button. The main drive motor can be running with a moment. (With the main motor rotation lever is set in the neutral position.)

3. Coolant pump ON/OFF push button.

4. Press the RED button to stop the main motor and coolant pump.

Check the rotating direction of spindle after wiring:

1. Turn on the power switch.

2. Slightly push "INTREMITENT" button.

3. Look at the rotating direction of Main Spindle from Tailstock.

4. If it is of anti-clockwise, you've got a right wiring.

5. If oppositely, exchange any of two wires among R", "S", "T" terminals.

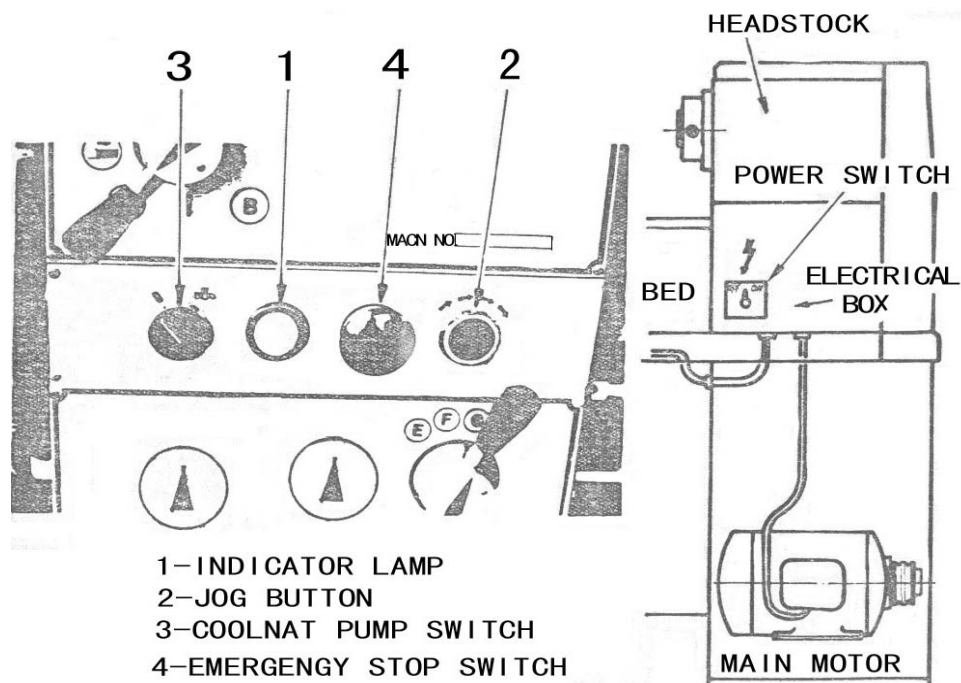

Fig.10

12. Speed Controls (2 Speed Motor)

Spindle speeds: Selected by the two lever controls and electrical switch, on the headstock and stand. The sixteen available speeds are shown directly on the data plate. While the electrical switch set at (1) position, the small lever rotated right-hand side, it provides speeds from 1800-510r.p.m., and rotated to left-hand side, it provides speeds from 330-90r.p.m. Then move the large lever to the appropriately colored arrow aligned with the required speed on the data plate. While the electrical switch set at (2) position, it provides speeds from 900-255 R.P.M. and 165-45 R.P.M. When the small lever set at upper or bottom position, the spindle is free for hand rotation.

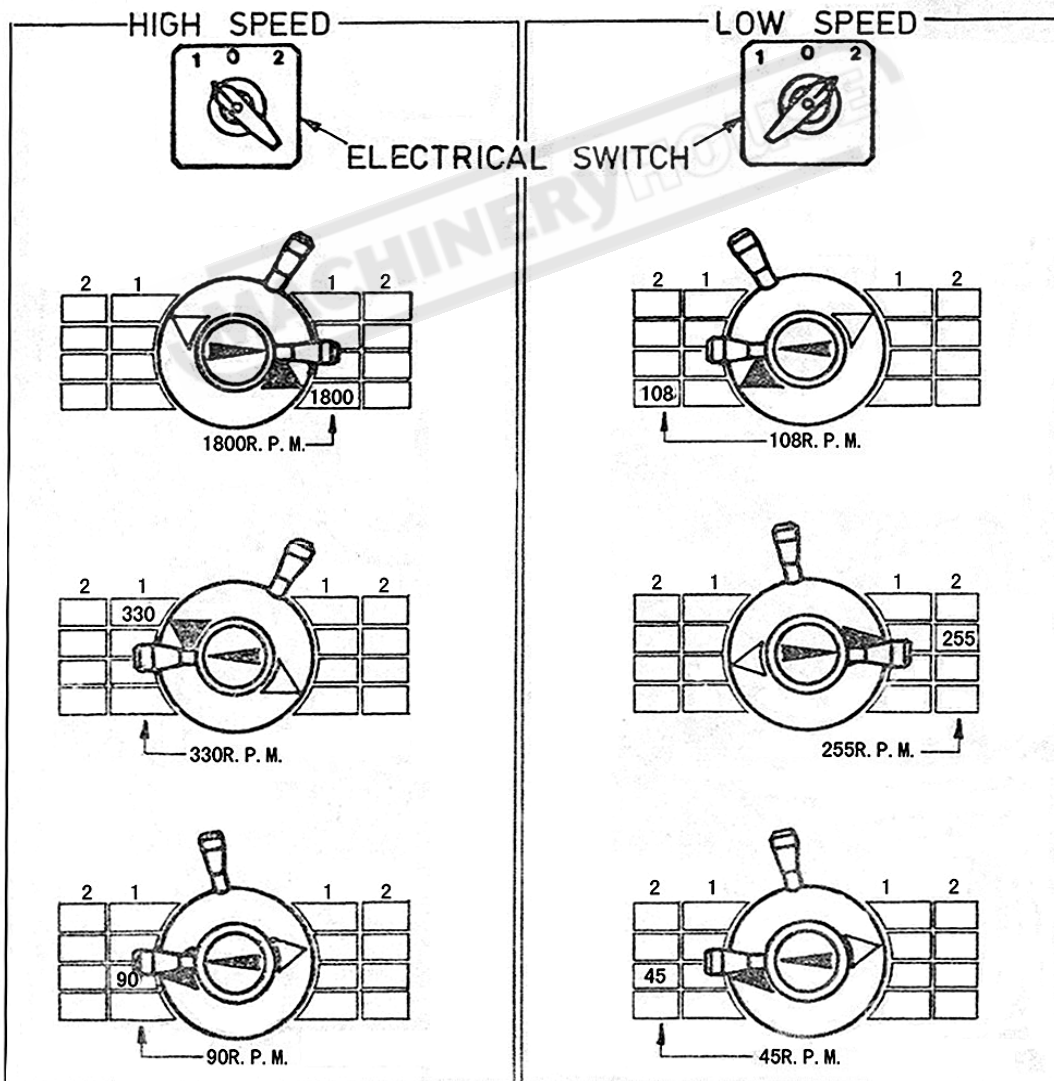

Fig.11

13. Threading Dial Indicator

A. Whitworth threads

Located on right-hand side of the apron on lathes having an Imperial leadscrew. Engage the indicator pinion with the leadscrew and tighten the hand nut to retain indicator in engagement.

To cut threads of an even number per inch, close the leadscrew nut as ANY line on the dial passes the datum mark. To cut threads of odd numbers per inch, close the leadscrew nut at any NUMBERED line.

Fractional threads of 1/2 or 1/4 T.P.I. may be cut by closing the nut at the SAME numbered line on each pass of the tool.

This dial cannot be used with an Imperial leadscrew to cut metric threads, or fractional threads. For these the leadscrew nut must be kept closed and the machine reversed by use of the changeover switch, after each cutting pass and tool with drawl.

Leadscrew Pitch 6mm

Leadscrew Pitch 4T.P.I

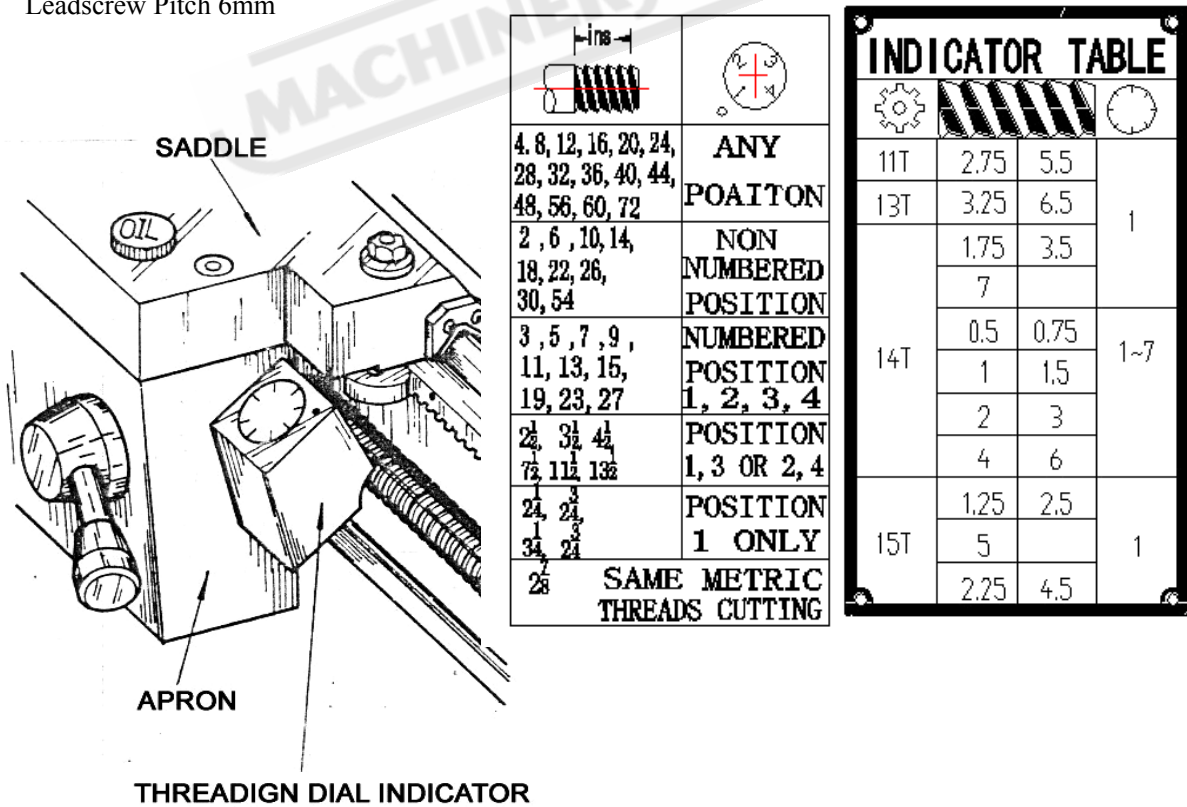

Fig.12

B. Metric threads

Same as above when a Metric Screw is installed.

To provide for the various pitches of metric threads, several gears having different numbers of teeth are mounted on the lower end of the shaft. The

vertical position of the thread dial indicator is changed as required so that the correct gear for the pitch of the thread to be cut will mesh with the leadscrew.

Each graduation on the dial is marked with a letter, which indicates the points at which the half nuts may be engaged for certain threads. A diagram is supplied with the thread dial to show which gear and graduations must be used for each pitch of metric screw thread.

14. Chucks and Chucks Mounting

When fitting chucks or faceplates, first ensure that spindle and chuck tapers are scrupulously clean and that all cams lock in the correct positions; see Fig.12. it may be necessary to re-set the cam lock studs (A) when mounting a new chuck. To do this, remove the cap-head locking screws (B) and set each stud so that the scribed ring (C) is flush with the rear face of the chuck-with the slot lining up with the locking screw hole. See Fig.13.

Now, mount the chuck or faceplate on the spindle nose and tighten the three cams in turn. When fully tightened, the cam lock line on each cam should be between the two V marks on the spindle nose. If any of the cams

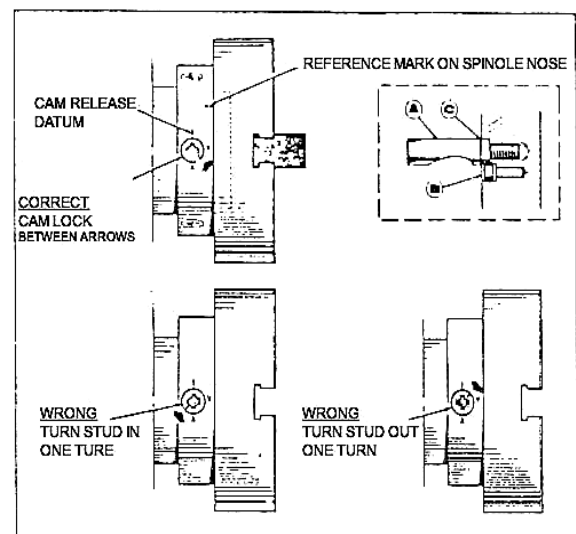

Fig.13

do not tighten fully within these limit marks, remove the chuck or

faceplate and re-adjust the stud as indicated in the illustration. Fit and tighten the locking screw (B) at each stud before remounting the chuck for work. A reference mark should be made on each correctly fitted chuck or faceplate to coincide with the reference mark scribed in the spindle nose. This will assist subsequent remounting.

IMPORTANT: Do Not Interchange Chucks or Face Plates Between Lathes Without Checking For Correct Cam Locking.

MACHINERYHOUSE

15. Electric Circuit Control

15.1 Wiring Diagram

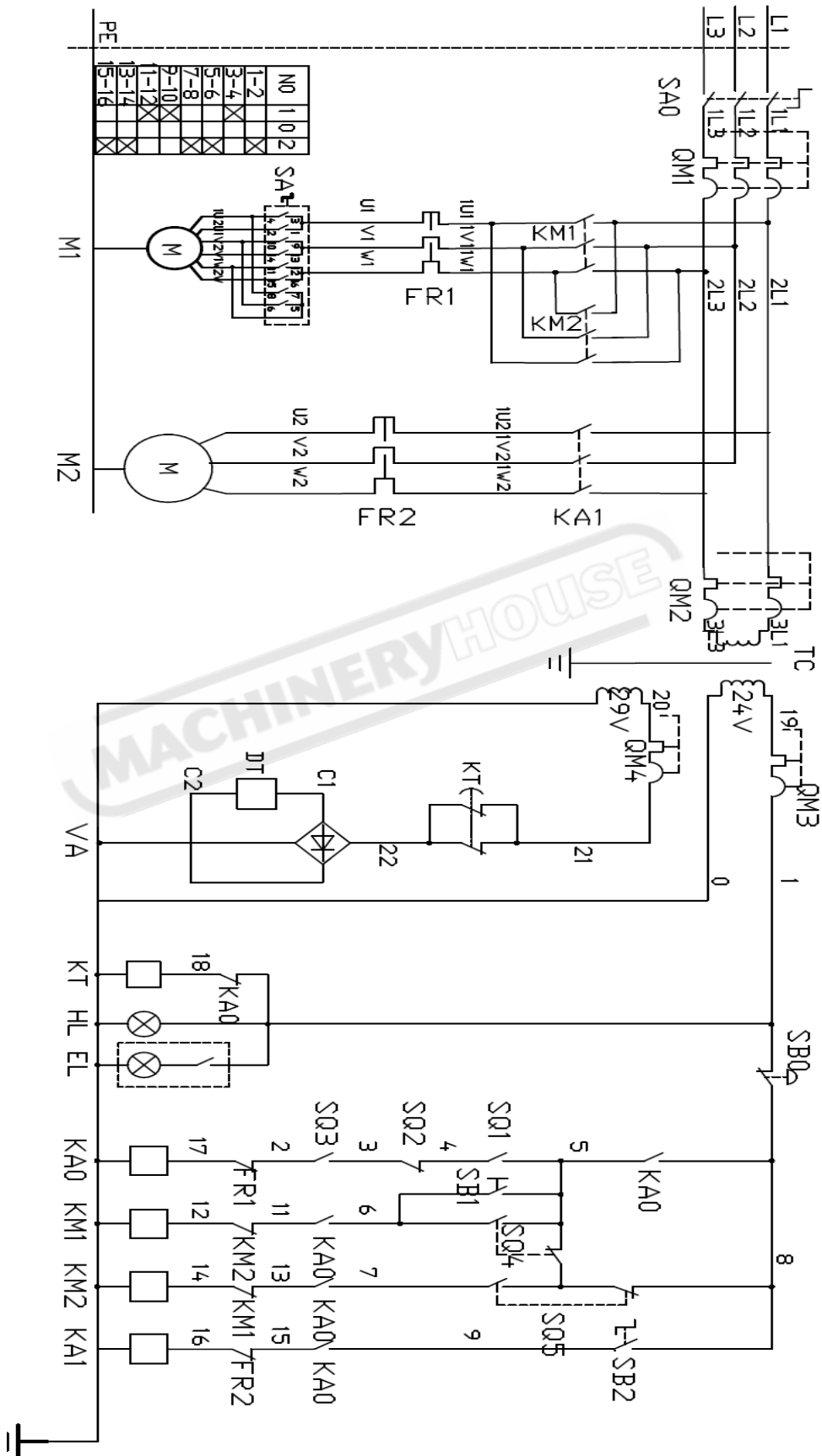

15.2 Electric Board Diagram

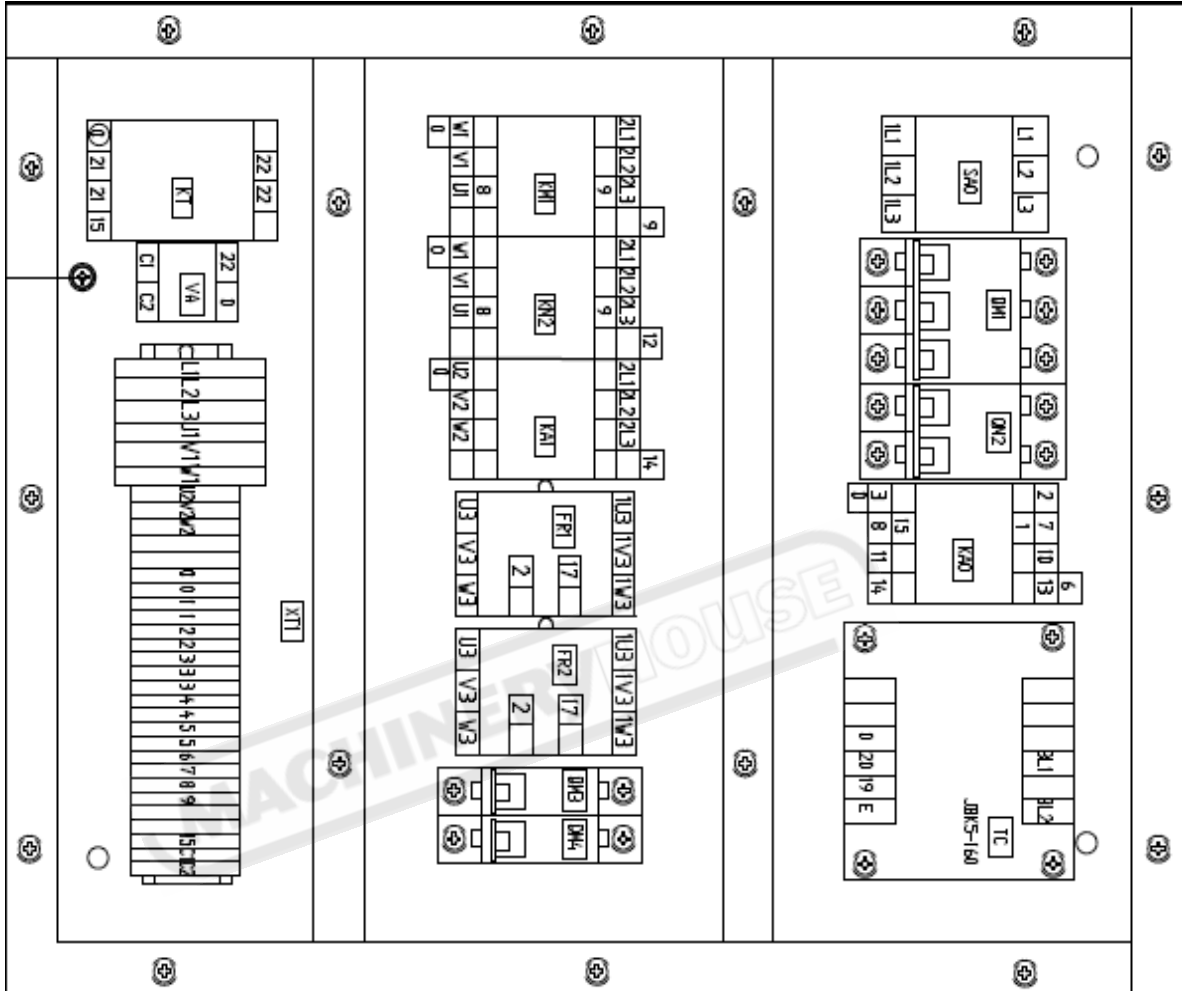

15.3 Electric Listing Component

No.	Type	Name	Specification	Qty
1	SA	High/Low/Stop Switch	LW8PS-25/M10T	1
2	SA0	Main Switch	LW8GS-25/30000-A	1
3	QM1	Breaker	GV2 2.5-4A	1
4	QM2	Breaker	DZ451-63 2P C1	1
5	QM3	Breaker	DZ451-63 1P C5	1
6	QM4	Breaker	DZ451-63 1P C2	1
7	FR1	Thermal overload relay	3UA5940 6.3-10A	1
8	FR2	Thermal overload relay	3UA5940 0.4-0.63A	1
9	KM1,2	AC Contactor	3TB4122 AC24V 50/60Hz	2
10	KA0	Relay	3TH8262 AC24V 50/60Hz	1
11	KA1	Relay	3TH8262 AC24V 50/60Hz	1
12	TC	Control Transformer	JBK5-160	1
13	KT	Time Relay	ST3PA AC24V	1
14	VA	Rectifier	3TQL 250V 12A	1
15	HL	Pilot Lamp	LA103-M/32 AC24V	1
16	EL	Working Lamp	JC34A AC24V	1
17	SQ4,5	Switch For FWD-REV	LXW5-11G2	2
18	SQ1	Switch For Brake	LXW5-11N1	1
19	SQ2	Switch For Chuck	LXW5-11Q1	1
20	SQ3	Switch For Position	QKS8-6080103201	1
21	SB0	Emergency Button	LA103-01ZS/1	1
22	SB1	Button	LA103-10/3	1
23	SB2	Button	LA103-10X/3	1
24	M1	Main Motor	YD132M2-8/4	1
25	M2	Coolant Pump	AB25	1

16 Bed assembly

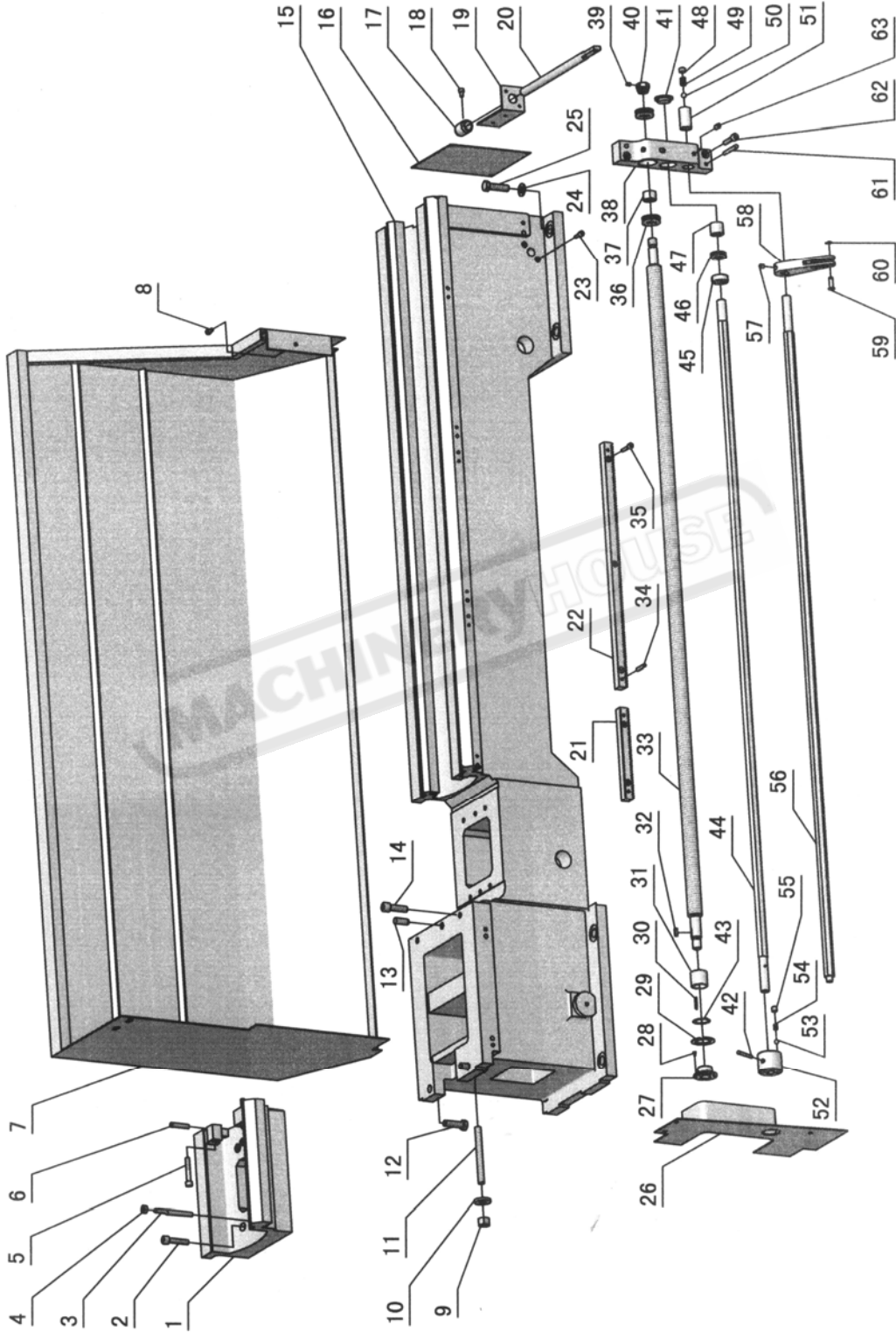

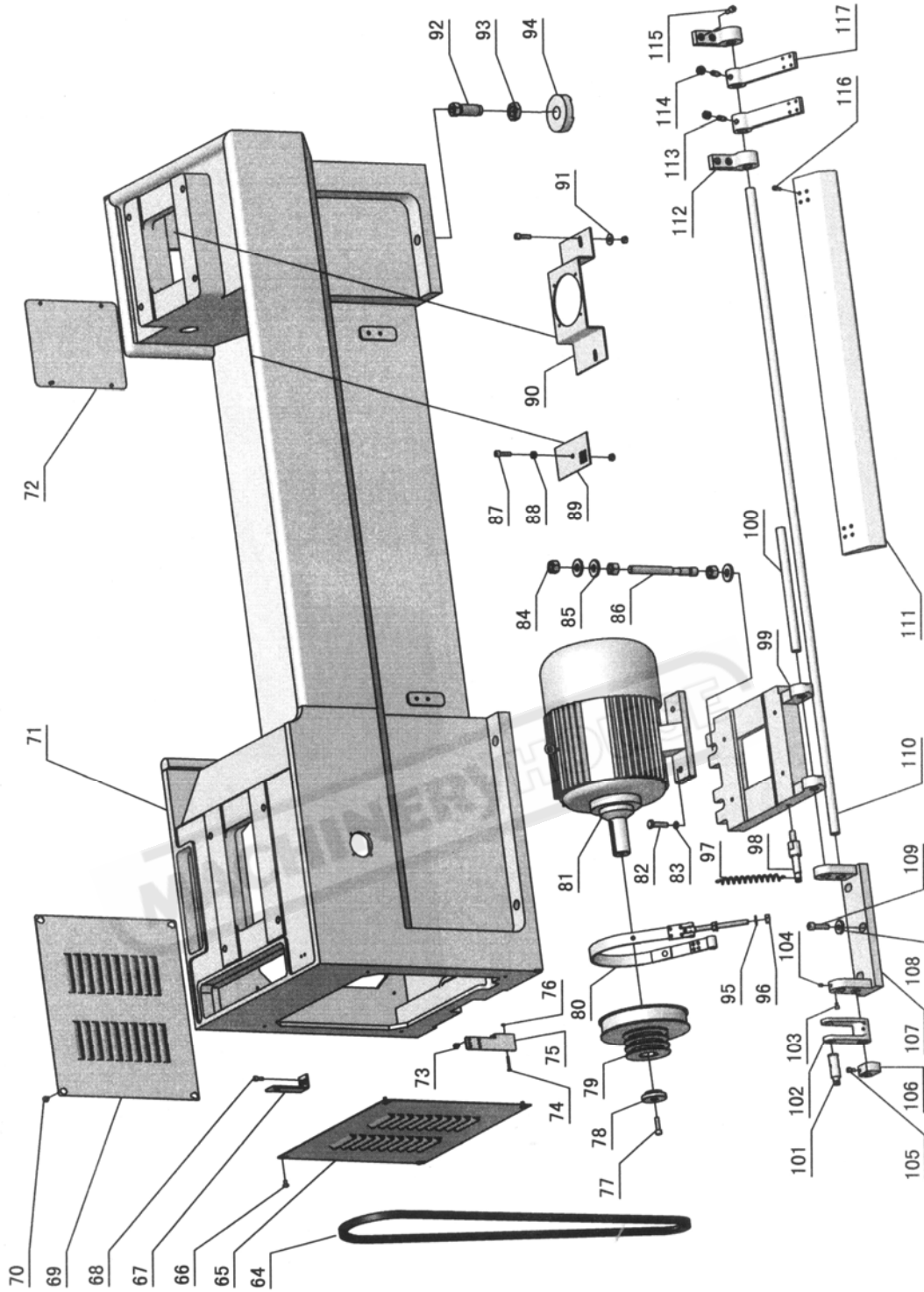

No.	Part No.	Name	Specification
1	CD6236-01-27	Gap Block	
2	GB70-85	Socket Head Cap Screw	M10×45
3	GB881-86	Taper Pin	8×85
4	GB6170-86	Nut	M8
5	GB70-85	Socket Head Cap Screw	M8×50
6	GB118-86	Pin	8×40
7	CD6236-01-26	Guard Assy	
8	GB70-85	Socket Head Cap Screw	M6×12
9	GB41-76	Nut	M14
10	CD6236-01-44	Washer	45
11	CD6236-01-43	Screw	
12	GB21-76	Bolt	M12×40
13	GB119-86	Pin	12×30
14	GB70-85	Socket Head Cap Screw	M12×40
15	CD6236-01-45	Bed	
16	CD6236-01-54	Cover	
17	CD6236-01-12	Block	
18	GB70-85	Socket Head Cap Screw	M6×10
19	CD6236-01-19	Hold	
20	CD6236-01-22	Rod	
21	CD6236-01-28	Rack	
22	CD6236-01-34	Rock	
23	GB70-85	Socket Head Cap Screw	M6×20
24	GB97.1-86	Washer	12
25	GB5783-86	Bolt	M12×45
26	CD6236-01-25	Cover	
27	CD6236-01-30	Sleeve	
28	CD6236-01-31	Pin	
29	CD6236-01-32	Washer	
30	GB2089-80	Spring	1.8×2.5×55
31	CD6236-01-33	Cover	
32	GB1567-86	Key	5×16
33	CD6236-01-37	Lead Screw(Inch)	
33	CD6236-01-37G	Lead Screw(Metric)	
34	GB879-86	Spring Pin	6×30
35	GB70-85	Socket Head Cap Screw	M6×30
36	GB301-84	Thrust Bearing	8203
37	CD6236-01-39	Sleeve	
38	CD6236-01-42	Bracket	
39	GB78-85	Set Screw	M6×8

No.	Part No.	Name	Specification
40	CD6236-01-41	Nut	
41	CL6132-06-11	Plug	
42	GB117-86	Taper Pin	5×45
43	GB894.2-86	External circlip	28
44	CD6236-01-36	Feed Rod	
45	CD6236-01-38	Sleeve	
46	GB301-84	Thrust Bearing	8103
47	CD6236-01-40	Sleeve	
48	GB77-85	Set Screw	M12×8
49	GB2089-80	Spring	1×9×20
50	GB308-84	Steel Ball	9.5
51	CD6236-01-55	Sleeve	
52	CD6236-01-29	Clutch	
53	GB308-84	Steal Ball	8
54	GB2089-80	Spring	1.2×6×46
55	GB77-85	Screw	M10×10
56	CD6236-01-35	Started Rod	
57	GB77-85	Screw	M8×8
58	CD6236-01-23	Lever	
59	CD6236-01-21	Pin	
60	GB896-86	Circlip	6
61	GB117-86	Taper Pin	6×50
62	GB70-85	Socket Head Cap Screw	M8×35
63	GB80-85	Screw	M8×14
64	GB1171-74	V13-1890	
65	RUN6141-106028	Cover	
66	GB818-85	Cross Screw	M6×10
67	RUN6246-108078	Limited Switch Seat	
68	GB70-85	Socket Head Cap Screw	M6×16
69	RUN6141-106028-01	Cover	
70	GB818-85	Cross Screw	M6×10
71	CD6236-01-01A	Stand	
72	RUN6246-106033	Cover	
73	GB818-85	Cross Screw	M6×10
74	GB818-85	Screw	M4×30
75	CD6236-01-59	Limited Switch Seat	
76	GB6172-86	Nut	M4
77	GB70-85	Socket Head Cap Screw	M8×30
78	RUN6141-106049a	Washer	
79	CD6236-01-05	Belt Pulley	

No.	Part No.	Name	Specification
80	RUN6141-106047	Belt Brake	
81	Y132M-8/4	Motor	
82	GB30-76	Bolt	M10×40
83	GB93-86	Washer	10
84	GB41-76	Nut	M16
85	RUN6141-106079	Washer	
86	RUN6141-106046	Screw	
87	GB70-85	Socket Head Cap Screw	M8×30
88	GB6170-86	Nut	M8
89	RUN6246-106051	Screen	
90	RUN6246-106090A	Coolant Pump Seat	
91	GB96-85	Washer	8
92	RUN6246-106029	Bolt	
93	GB6173-86	Nut	M24×2
94	RUN6246-106069	Block-Leveling	
95	GB97.1-85	Washer	10
96	GB6170-86	Nut	M10
97	Q81-3	Spring	3×16×115
98	RUN6246-106050	Shaft	
99	RUN6141-106034	Motor Seat	
100	RUN6246-106044	Shaft	
101	RUN6141-106039	Shaft	
102	RUN6141-106040	Arm Brake	
103	GB70-85	Socket Head Cap Screw	M5×8
104	GB80-85	Screw	M6×8
105	GB70-85	Socket Head Cap Screw	M6×12
106	RUN6141-106037	Cam	
107	RUN6141-106041	Bracket Motor Seat	
108	RUN6246-106097	Washer	
109	GB70-85	Screw	M10×40
110	RUN6141-106050	Shaft	
111	CD6236-01-51	Pedal Brake	
112	RUN6141-106036	Bracket	
113	GB79-85	Screw	M10×25
114	GB6170-86	Nut	M10
115	GB70-85	Screw	M8×20
116	GB70-85	Screw	M6×16
117	RUN6141-106042	Arm	

17. Change gear

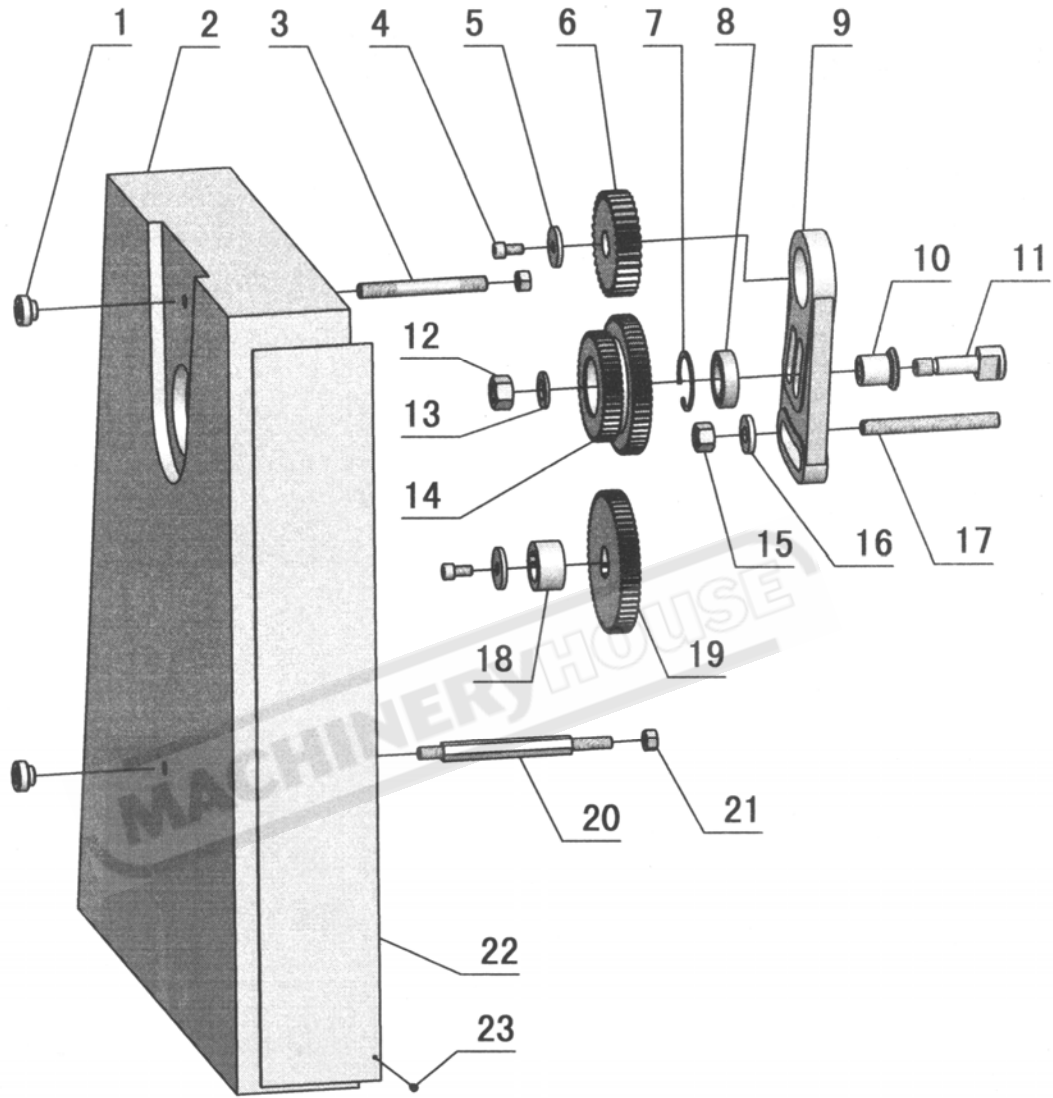

No.	Part No.	Name	Specification
1	CL6132-04-77	Nut	
2	CD6236-04-72	Cover(360)	
2	CD6240-04-72	Cover(410)	
3	GB900-88	Bolt	M10×85
4	GB70-85	Socket Head Cap Screw	M8×16
5	CD6240-05-02	Washer	
6	CD6240-04-53G1	Change Gear	Metric(33T)
6	CD6236-04-53	Change Gear(360)	Inch(24T)
6	CD6240-04-53	Change Gear(410)	Inch(24T)
7	GB893.1-86	Circlip	47
8	GB279-88	Roller Bearing	160105
9	CD6240-05-10	Swing France	
10	CD6236-05-06	Sleeve	
11	CD6236-05-05	Shaft	
12	GB6172-86	Nut	M14
13	GB97.1-84	Washer	14
14	CD6240-05-09G1	Change Gear	Metric(35/48T)
14	CD6236-05-09	Change Gear(360)	Inch(44/52T)
14	CD6240-05-09	Change Gear(410)	Inch(44/52T)
15	GB41-76	Nut	M14
16	CD6236-01-44	Washer	45
17	CD6236-01-43	Screw	
18	CD6236-05-03	Sleeve	
19	CD6240-05-04G1	Change Gear	Metric(54T)
19	CD6236-05-04	Change Gear(360)	Inch(57T)
19	CD6240-05-04	Change Gear(410)	Inch(57T)
20	CD6236-01-24	Bolt	
21	GB54-76	Nut	M10
22	CD6236-04-71	Plate	
23	GB818-85	Screw	M3×8

18. Headstock Assembly

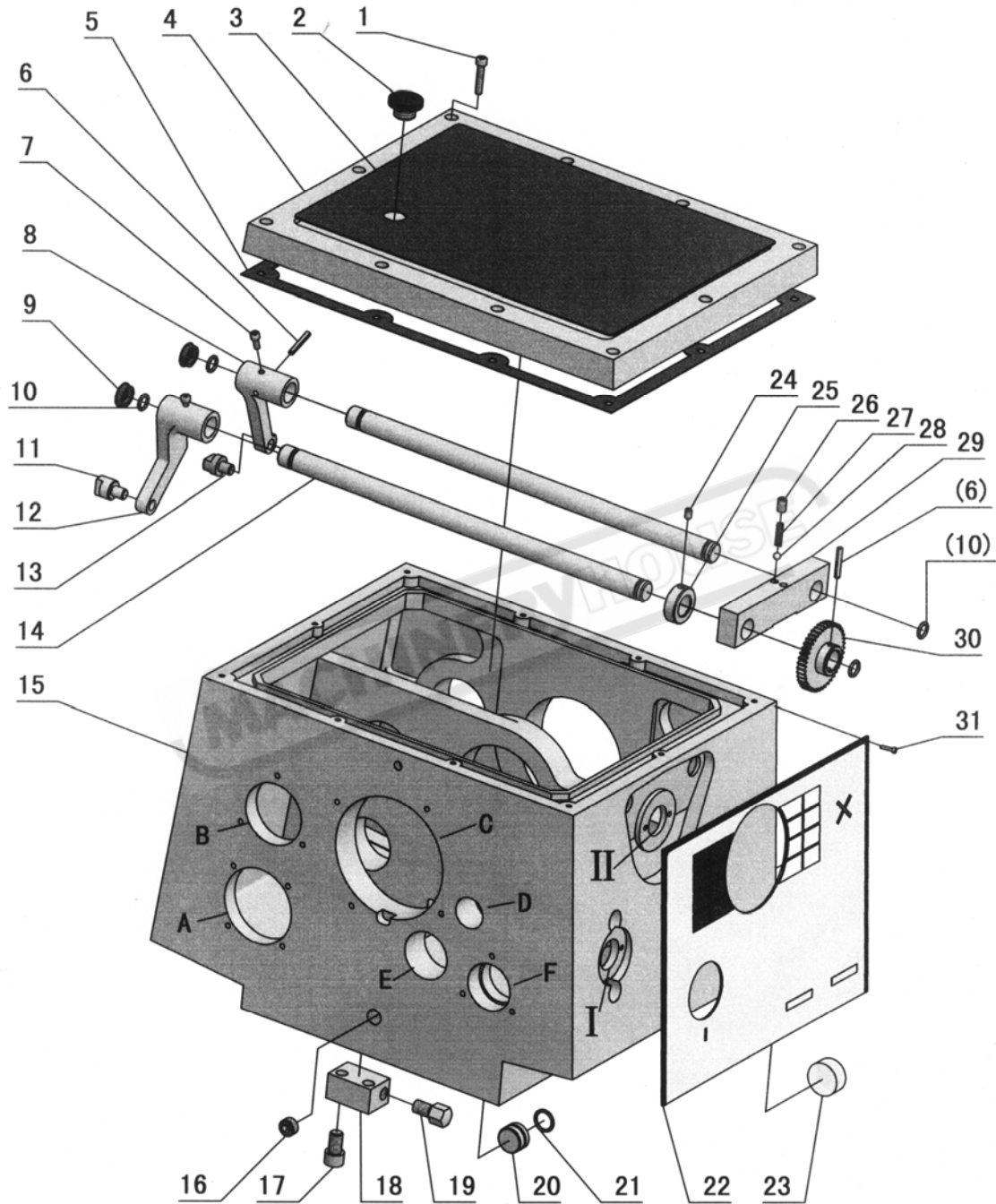

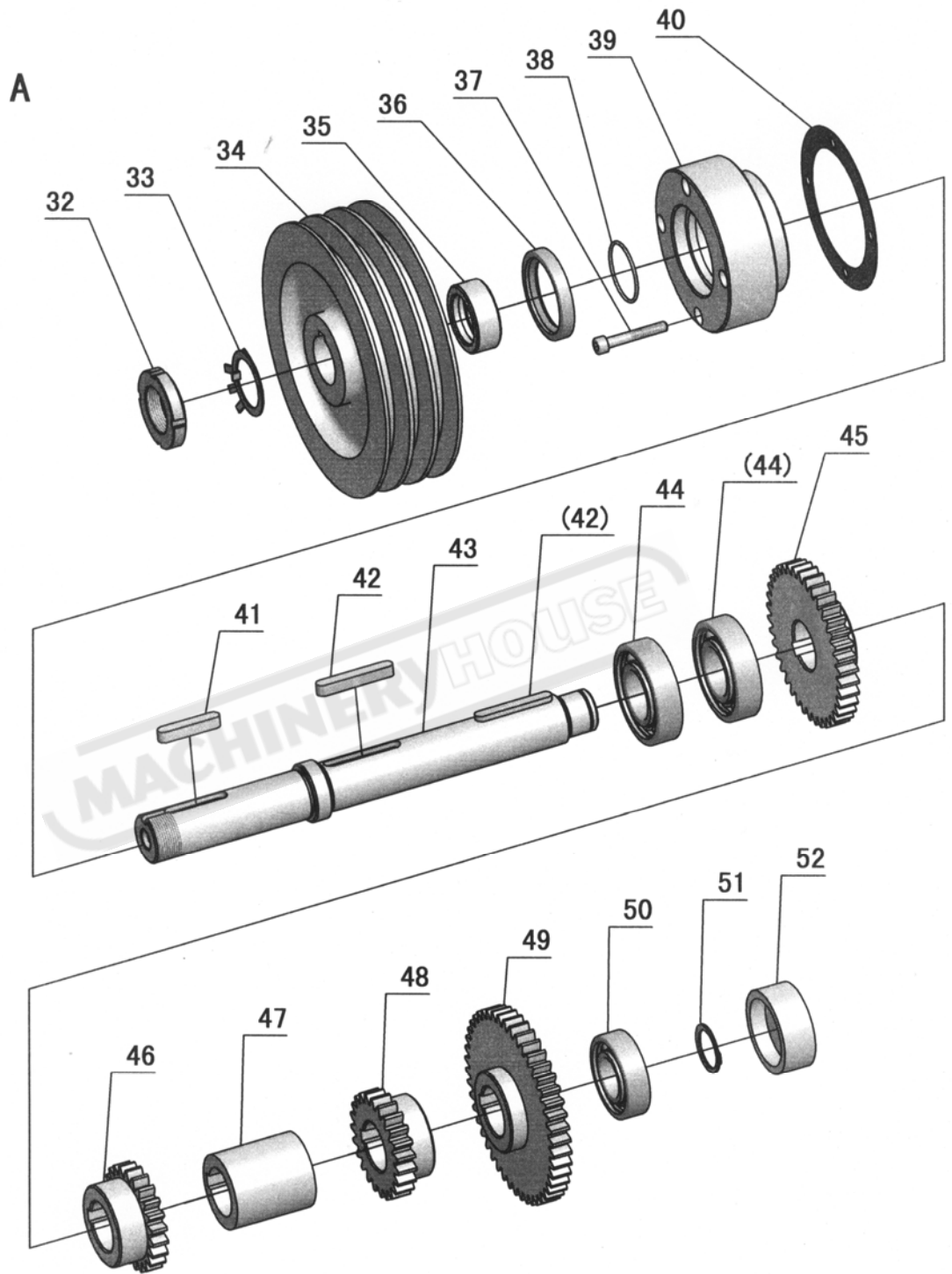

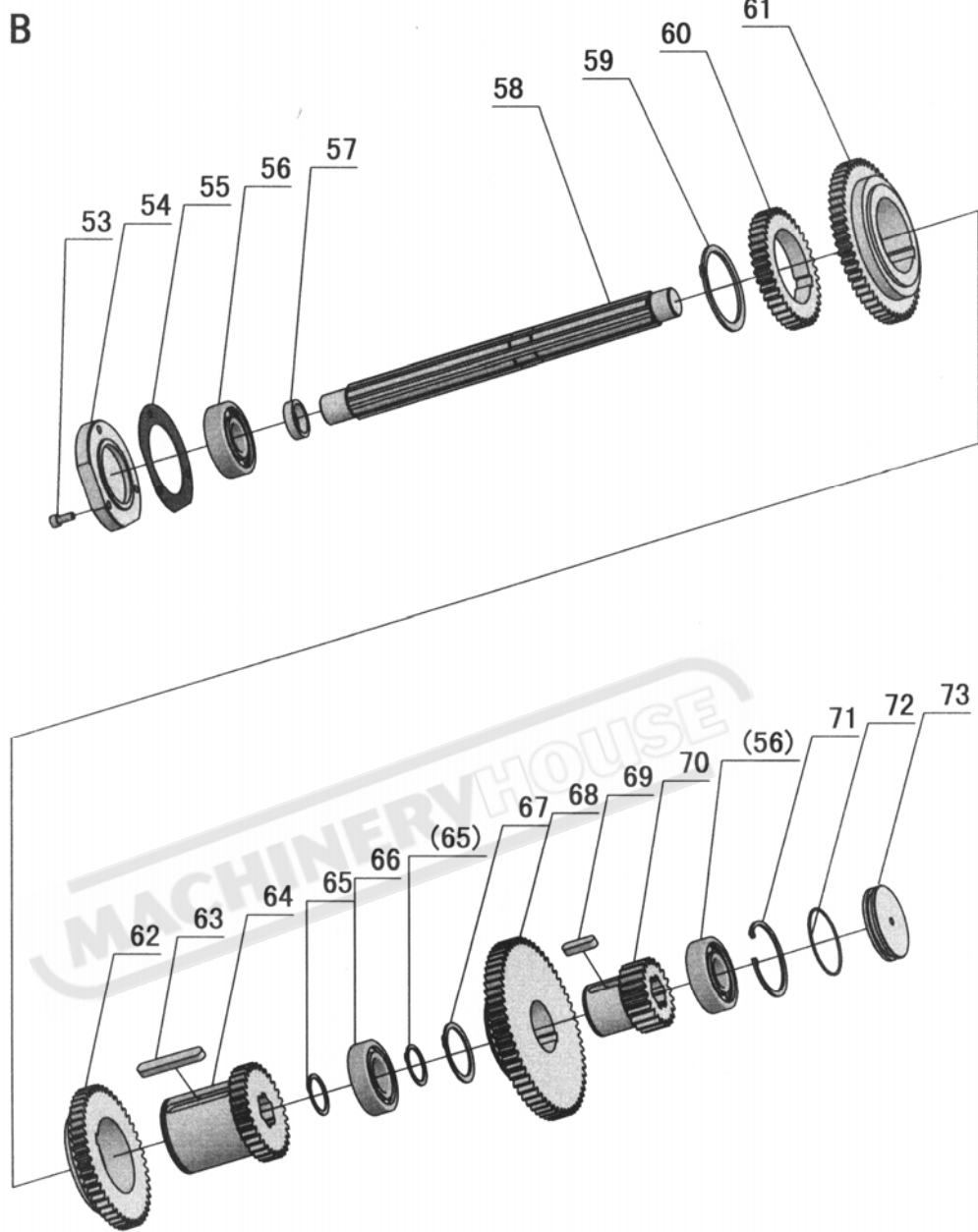

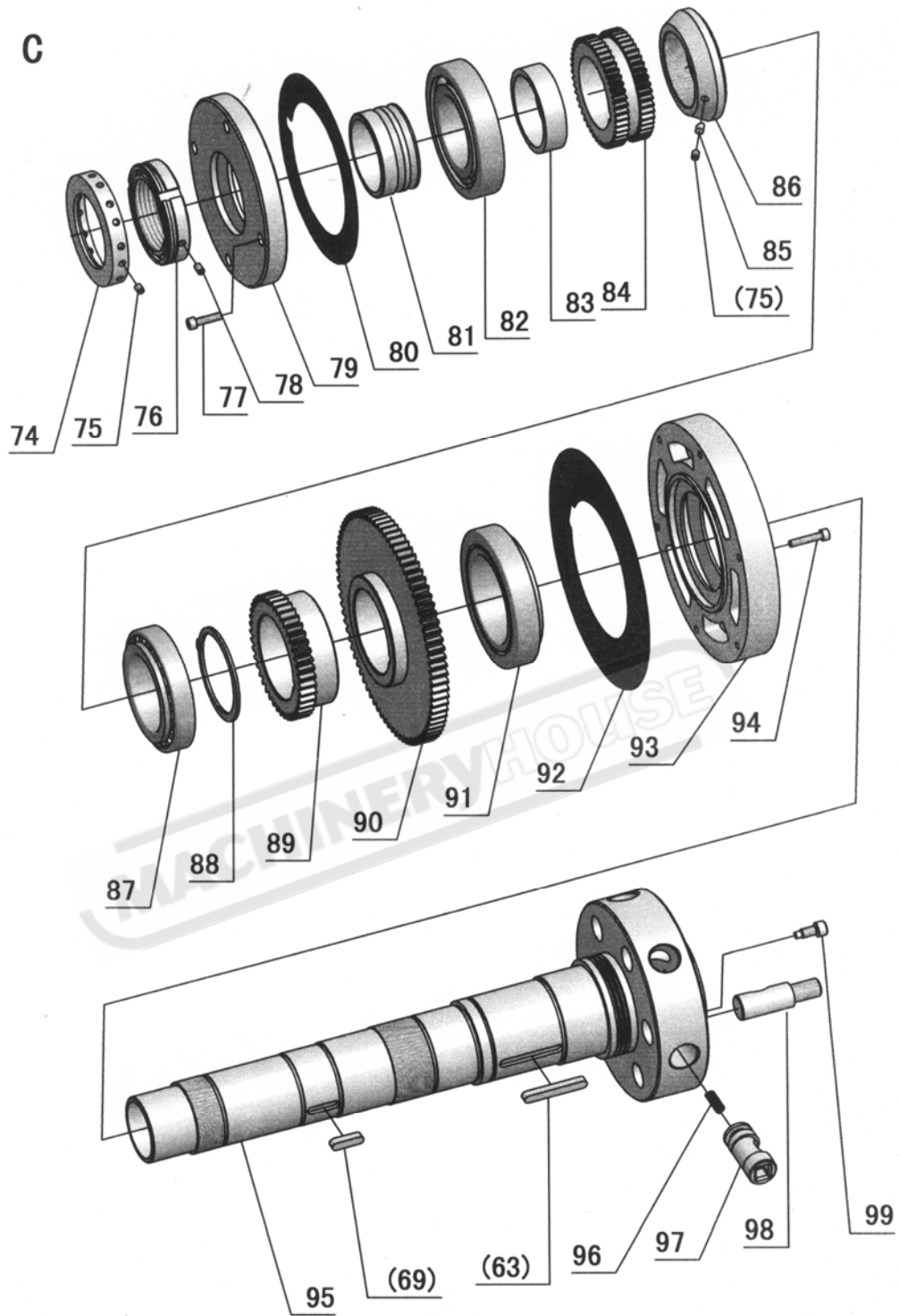

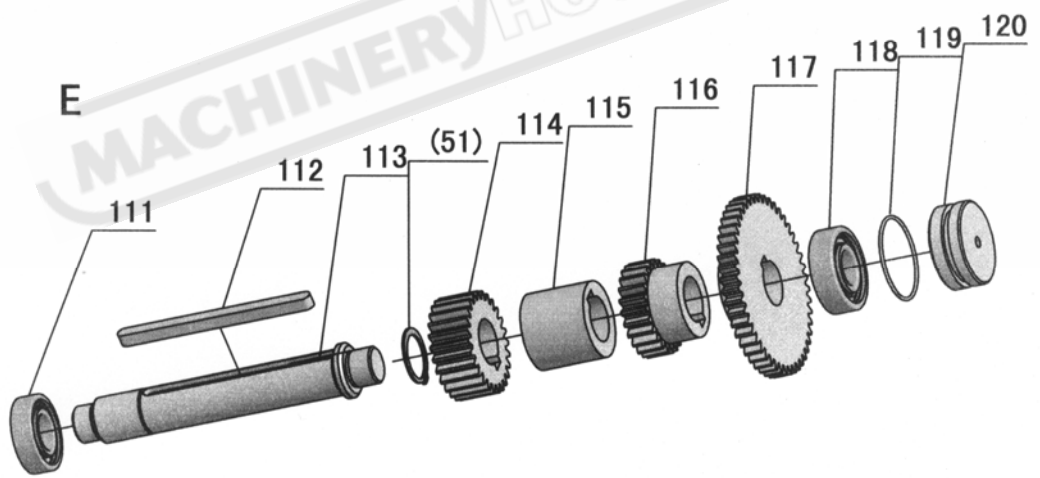
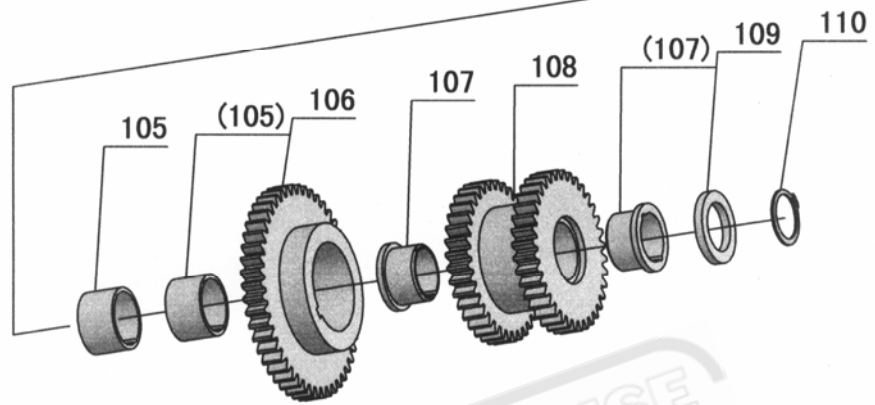
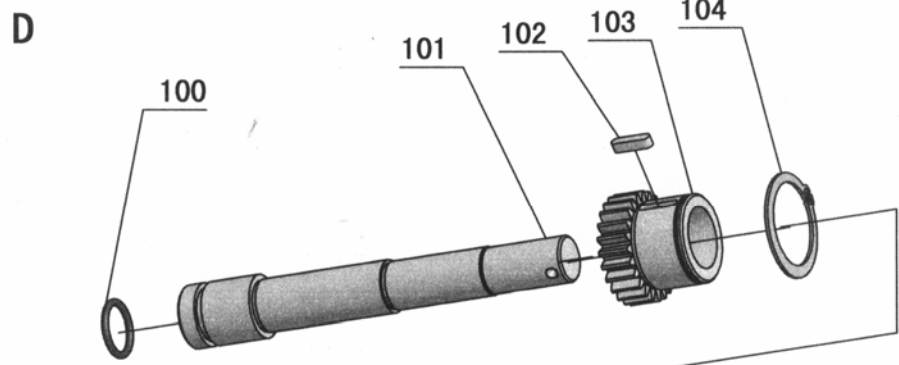

MACHINERYHOUSE

F

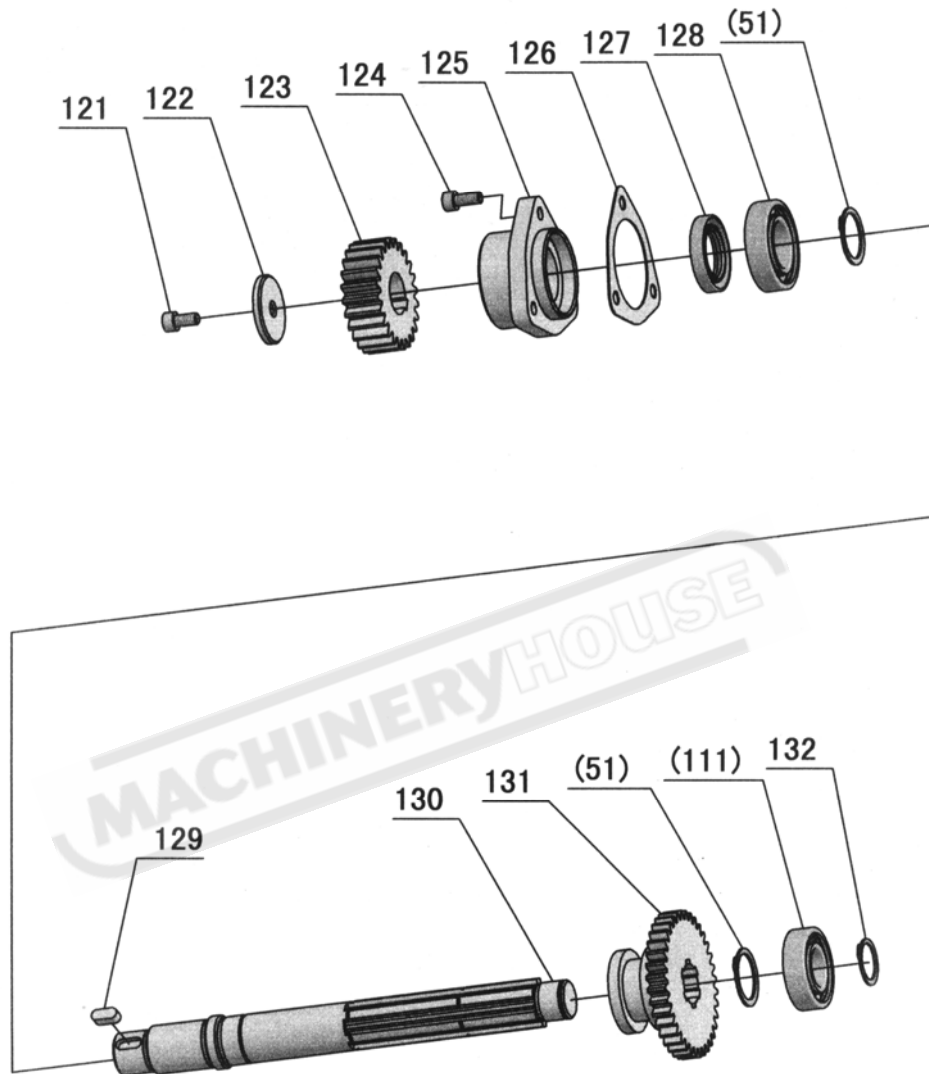

I

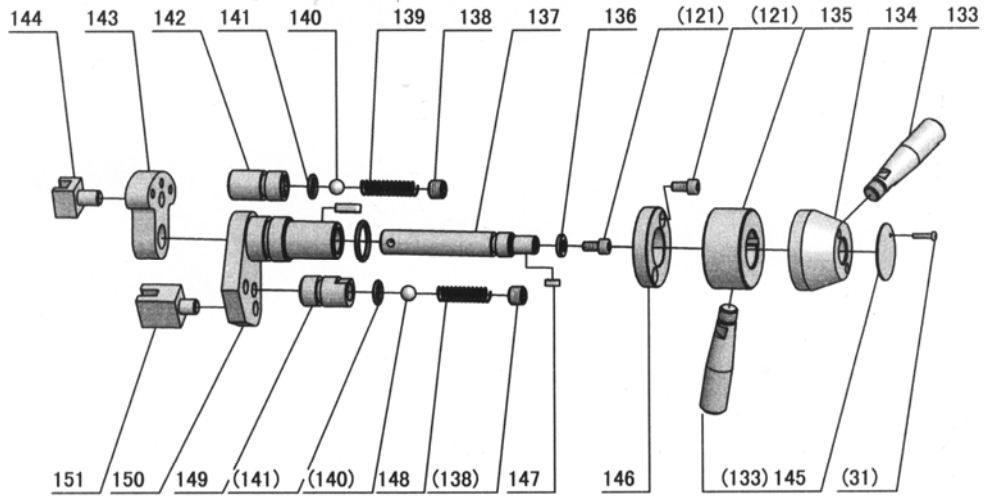

II

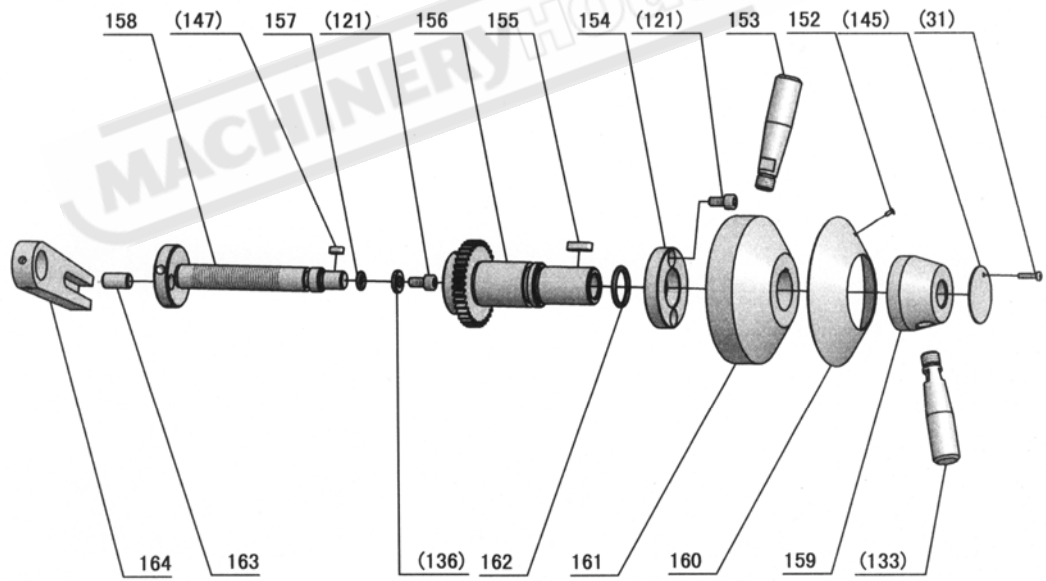

No.	Part No.	Name	Specification
1	GB70-85	Socket Head Cap Screw	M6×30
2	CL6132-04-06	Plug-Oil Inlet	
3	CD6236-04-19	Cover Dress	
4	CD6236/6240-04-15	Headstock Cover(360/410)	
5	CD6236/6240-04-14	Packing(360/410)	
6	GB879-85	Spring Pin	5×30
7	GB70-85	Socket Head Cap Screw	M5×16
8	CD6236-04-74	Bracket	
9	CL6132-04-03	Plug	
10	GB3452.1-82	O-Ring	14×2.65
11	CD6236-04-22	Fork	
12	CD6236-04-21	Lever	
13	CL6132-04-76	Fork	
14	CD6236-04-20	Shaft	
15	CD6236/6240-04-16	Headstock(360/410)	
16	Q/ZB285.3	Oil Plug	ZG 3/8"
17	GB70-85	Screw	M12×20
18	CD6236-04-73	Limited Bracket	
19	CL6132-04-82	Adjust Screw	
20	CL6132-04-40	Plug	
21	GB3452.1-82	O-Ring	19×2.65
22	CD6236-04-13	Plate	
23	GB1160.1-86	Oil Sight	16
24	GB80-85	Fix Screw	M6×10
25	CL6132-04-99	Sleeve	
26	GB77-85	Screw	M8×12
27	GB2089-80	Spring	1×5×22
28	GB308-84	Steel Ball	6.5
29	CD6236-04-18	Bracket	
30	CD6236-04-17	Gear	Mn=2.5 Z=43
31	GB818-85	Cross Recessed Head Screw	M3×15
32	GB812-88	Nut	M30×1.5
33	GB858-88	Toothed Lock Washer	30
34	CD6236-04-02	Belt Pulley	
35	RUN6246-101009	Spacer	
36		Oil Seal	TC55×42×9
37	GB70-85	Socket Head Cap Screw	M6×40
38	GB1235-76	O-Ring	36×3.5
39	RUN6246-101010	Bearing Cover	
40	RUN6246-101010-1	Packing	

No.	Part No.	Name	Specification
41	GB1096-79	Key	8×40
42	GB1096-79	Key	8×50
43	CD6236-04-01	Shaft	
44	GB278-89	Ball Bearing	80206
45	CD6236-04-03	Gear	Mn=2.5 Z=38
46	CD6236-04-04	Gear	Mn=2.5 Z=33
47	CD6236-04-05	Sleeve	
48	CD6236-04-06	Gear	Mn=2.5 Z=23
49	CD6236-04-07	Gear	Mn=2.5 Z=33
50	GB278-89	Ball Bearing	80205
51	GB894.1-86	External Circlip	25
52	CD6236-04-08	Plug	
53	GB70-85	Socket Head Cap Screw	M6×14
54	CD6236-04-68	Cover	
55	CD6236-04-67	Packing	
56	GB278-89	Ball Bearing	80305
57	CD6236-04-69	Spacer	
58	CD6236-04-09	Shaft	
59	GB894.1-86	External Circlip	65
60	CD6236-04-63	Gear	Mn=2.5 Z=39
61	CD6236-04-64	Gear	Mn=2.5 Z=54
62	CD6236-04-65	Gear	Mn=2.5 Z=47
63	GB1096-79	Key	8×60
64	CD6236-04-66	Gear	Mn=2.5 Z=31
65	GB894.1-86	External Circlip	30
66	GB276-89	Ball Bearing	E206
67	GB894.1-86	External Circlip	45
68	CD6236-04-10	Gear	Mn=2.5 Z=60
69	GB1096-79	Key	8×30
70	CD6236-04-11	Gear	Mn=2.5 Z=21
71	GB893.1-86	External Circlip	62
72	GB1235-76	O-Ring	56×3.5
73	CD6236-04-12	Cover	
74	CD6236-04-62	Balance Piece	
75	GB77-85	Fix Screw	M6×8
76	CD6236-04-61	Set Nut	
77	GB70-85	Socket Head Cap Screw	M6×25
78	GB77-85	Fix Screw	M6×10
79	CD6236-04-58	Cover	
80	CD6236-04-59	Packing	

No.	Part No.	Name	Specification
81	CD6236-04-60	Cycle Oil Ring	
82	GB276-89	Ball Bearing	E213
83	CD6236-04-57	Sleeve	
84	CD6236-04-56	Gear	Mn=2 Z=48
85	CD6236-04-34	Fix Black	
86	CD6236-04-33	Set Nut	
87	GB297-84	Taper Roller	D2007114E
88	GB894.1-86	External Circlip	75
89	CD6236-04-35	Gear	Mn=2.5 Z=43
90	CD6236-04-36	Gear	Mn=2.5 Z=82
91	GB297-84	Taper Roller	D2007116E
92	CD6236-04-38	Packing	
93	CD6236-04-37	Cover	
94	GB70-85	Socket Head Cap Screw	M6×30
95	CD6236-04-39	Spindle	D1-6
96	RUN6246-101082-1	Spring	
97	RUN6246-101081	Cam Lock	
98	RUN6246-101082	Cam Lock Stud	
99	RUN6246-101087	Screw	
100	GB1235-76	O-Ring	28×3.1
101	CD6236-04-40	Shaft	
102	GB1096-79	Key	5×20
103	CD6236-04-43-1	Gear	Mn=2 Z=24
104	GB894.1-86	External Circlip	42
105	CD6236-04-43-2	Bush	
106	CD6236-04-44	Gear	Mn=2 Z=48
107	CD6236-04-42-2	Bush	
108	CD6236-04-42	Gear	Mn=2 Z=36
109	CD6236-04-41	Spacer	
110	GB894.1-86	External Circlip	22
111	GB278-89	Ball Bearing	80104
112	GB1096-79	Key	8×115
113	CD6236-04-45	Shaft	
114	CD6236-04-46	Gear	Mn=2 Z=26
115	CD6236-04-47	Sleeve	
116	CD6236-04-48	Gear	Mn=2 Z=24
117	CD6236-04-49	Gear	Mn=2 Z=48
118	GB278-89	Ball Bearing	80204
119	GB1235-76	O-Ring	46×3.5
120	CD6236-04-55	Cover	

No.	Part No.	Name	Specification
121	GB70-85	Socket Head Cap Screw	M6×12
122	CD6236-04-54	Spacer	
123	CD6240-04-53	Change Gear(410)	Inch(24T)
124	GB70-85	Socket Head Cap Screw	M6×14
125	CD6236-04-52	Cover	
126	CD6236-04-52	Packing	
127	HG4-692-67	Oil Seal	SD25×40×10
128	GB278-89	Ball Bearing	80105
129	GB1096-79	Key	6×14
130	CD6236-04-50	Shaft	
131	CD6236-04-51	Gear	Mn=2 Z=36
132	GB894.1-86	External Circlip	20
133	CD6236-05-63A	Lever	
134	CD6236-04-28	Lever Head	
135	CD6236-04-27	Lever Head	
136	CL6132-04-62	External Circlip	
137	CD6236-04-29	Shaft	
138	GB77-85	Fix Screw	M12×10
139	GB2089-80	Spring	0.9×9×40
140	GB308-84	Steel Ball	φ10
141	GB3452.1-82	O-Ring	14×2.65
142	CD6236-04-31	Bracket	
143	CD6236-04-30	Lever	
144	CD6236-04-32	Fork	
145	CL6132-04-90	Plate	
146	CD6236-04-26	Cover	
147	GB1096-79	Key	4×10
148	GB2089-80	Spring	0.9×9×35
149	CD6236-04-25	Bracket	
150	CD6236-04-24	Lever	
151	CD6236-04-23	Fork	
152	GB827-86	Rivet	2×5
153	CD6236-04-78A	Lever	
154	CL6132-04-68	Cover	
155	GB1096-79	Key	5×18
156	CD6236-04-77	Gear Shaft	Mn=1.5 Z=37
157	GB3452.1-82	O-Ring	10×2.65
158	CD6236-04-75	Lever Shaft	
159	CL6132-04-91	Lever Bracket	
160	CL6132-04-92	Plate	

No.	Part No.	Name	Specification
161	CL6132-04-98	Lever Bracket	
162	GB1235-76	O-Ring	28×3.1
163	CL6132-04-94	Pin	
164	CD6236-04-76	Bracket	

MACHINERYHOUSE

19. Gear Box Control

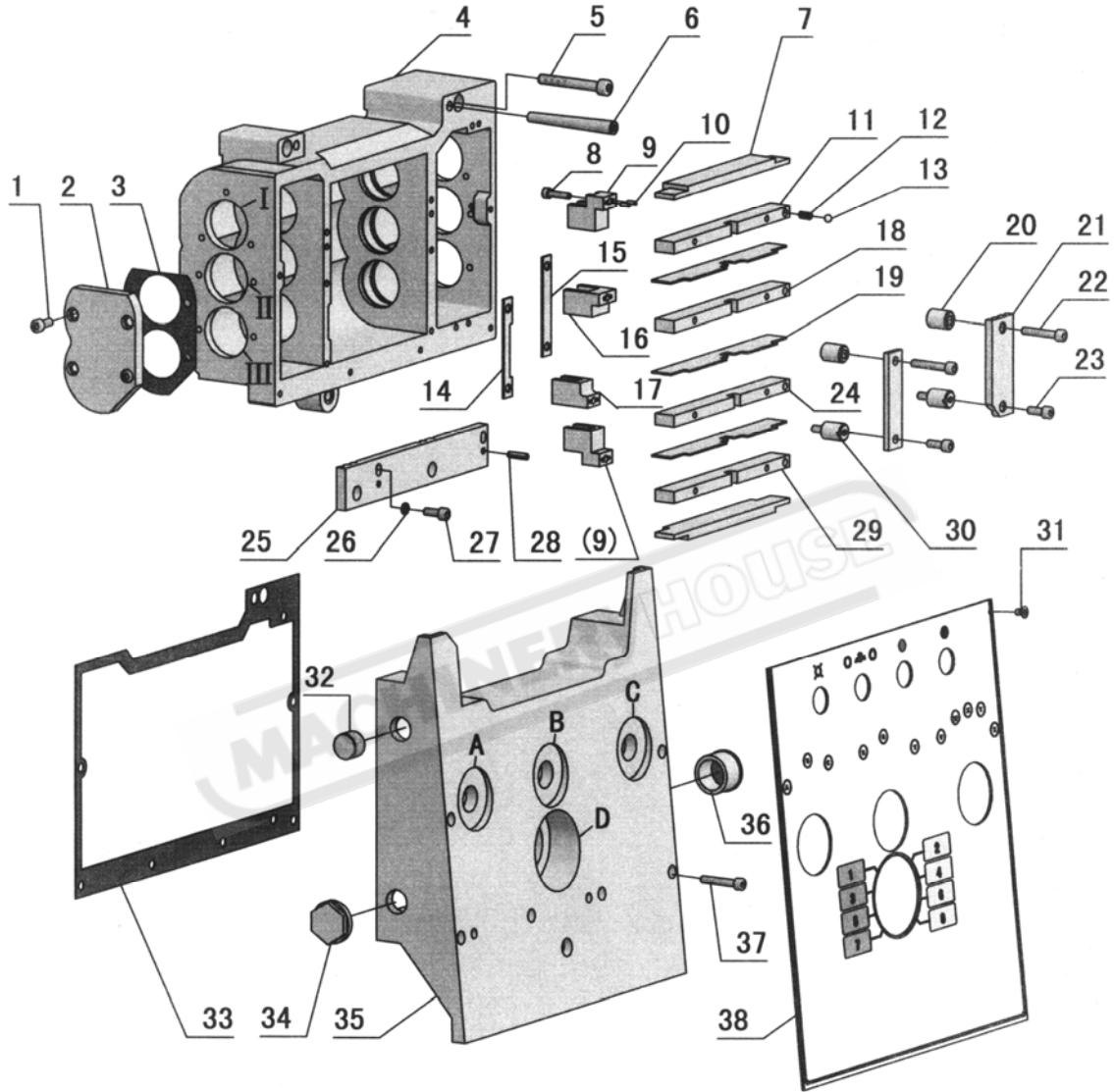

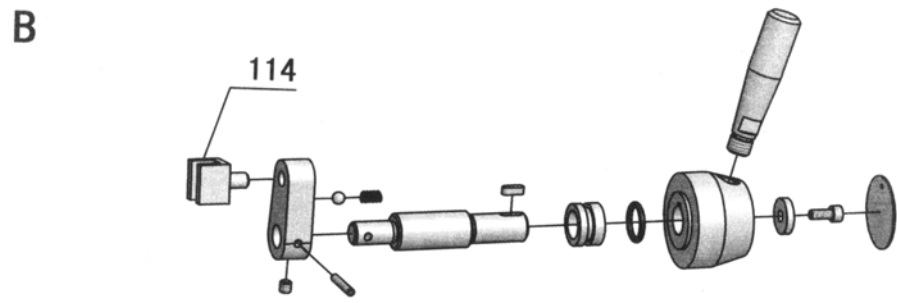
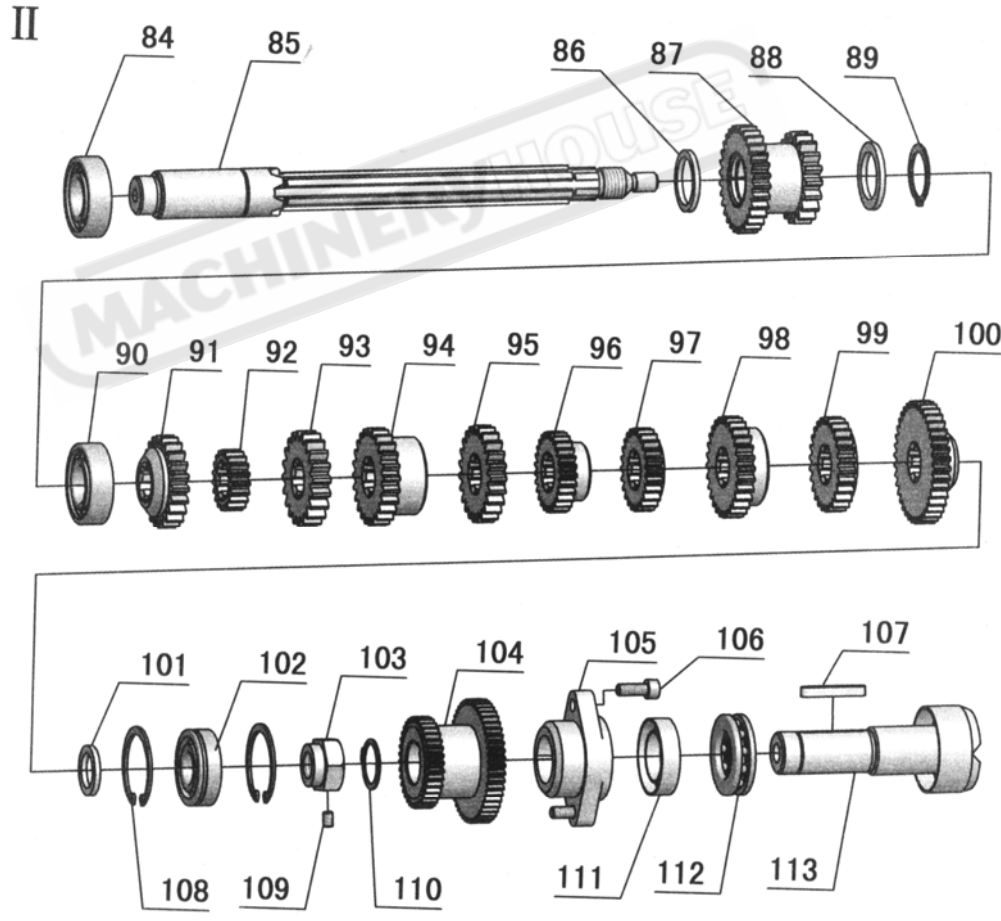
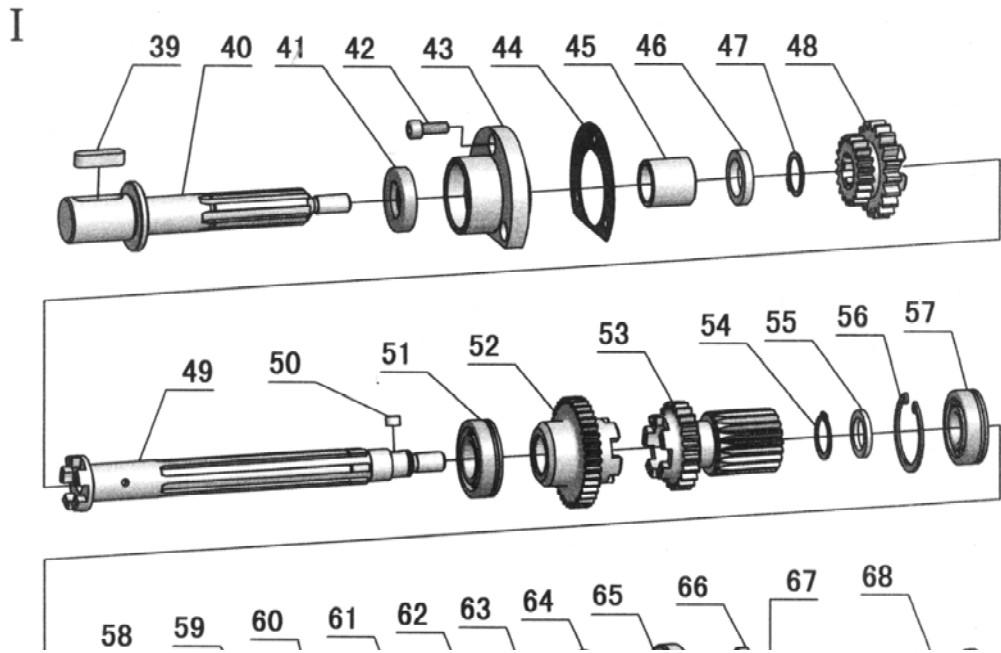

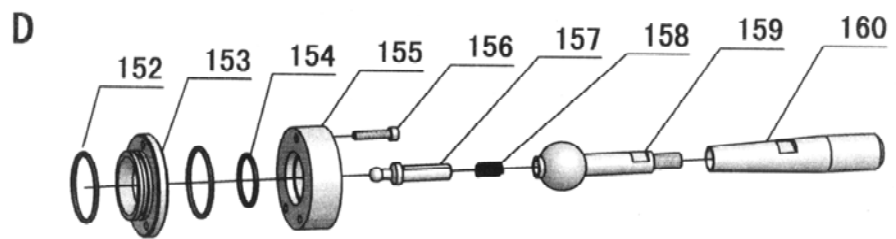
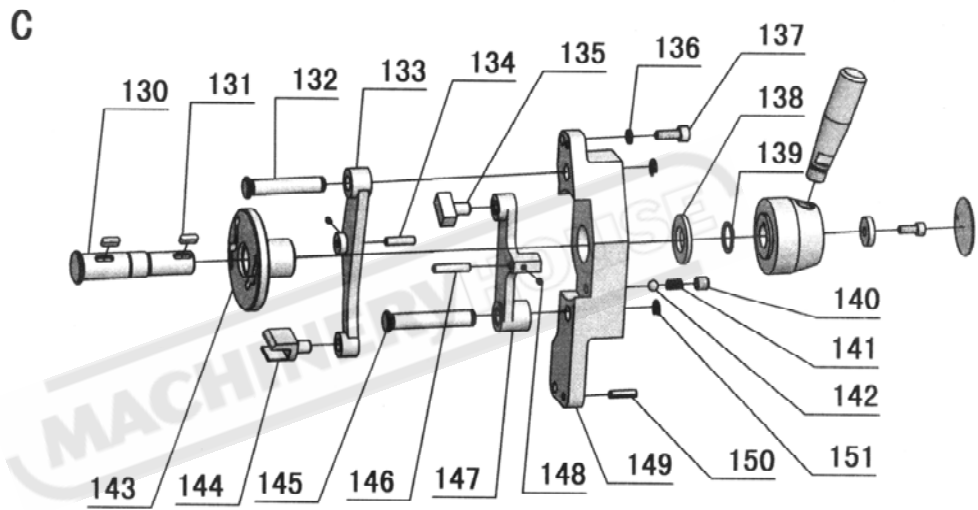
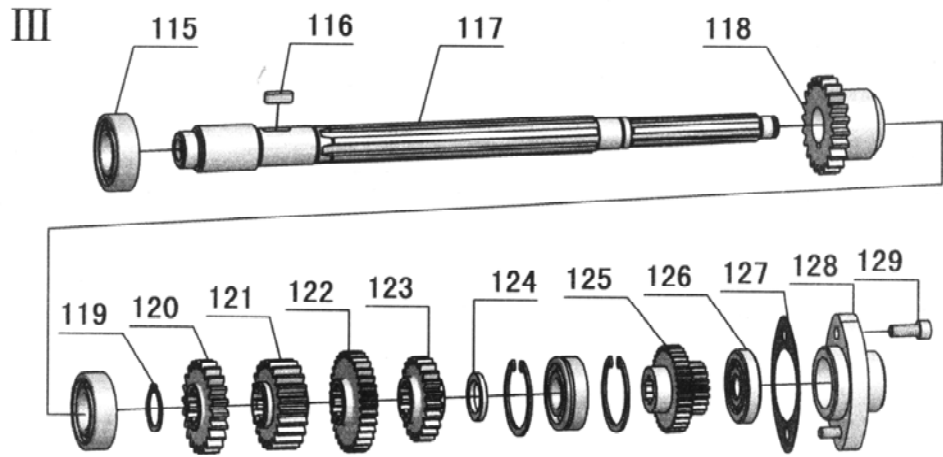

No.	Part No.	Name	Specification
1	GB70-85	Socket Head Cap Screw	M6×16
2	CD6236-05-91	Cover	
3	CD6236-05-65	Packing	
4	CD6236-05-42	Gear Box Casting	
5	GB70-85	Socket Head Cap Screw	M8×60
6	GB118-86	Taper Pin	A8×90
7	CD6236-05-58	Top Plate	
8	GB70-85	Socket Head Cap Screw	M5×20
9	CD6236-05-96	Fork	
10	GB879-86	Spring Pin	3×10
11	CD6236-05-56	Fork	
12	GB2089-80	Spring	0.8×5×17
13	GB308-84	Steel Ball	6
14	CD6236-05-92	Plate	
15	CD6236-05-97	Plate	
16	CD6236-05-95	Fork	
17	CD6236-05-94	Fork	
18	CD6236-05-55	Fork	
19	CD6236-05-57	Drive Plate	
20	CD6236-05-59	Sleeve	
21	CD6236-05-51	Set Screw	M6×5
22	GB70-85	Socket Head Cap Screw	M6×35
23	GB70-85	Socket Head Cap Screw	M6×16
24	CD6236-05-54	Fork	
25	CD6236-05-89	Selector Bar	
26	GB93-87	Spring Washer	6
27	GB70-85	Socket Head Cap Screw	M6×16
28	GB879-86	Spring Pin	5×18
29	CD6236-05-53	Fork	
30	CD6236-05-52	Screw	
31	GB819-85	Cross Screw	M5×8
32	GB3289.2-82	Oil Inlet Pip	ZG1/2"
33	CD6236-05-87	Packing	
34	GB3289.31-82	Plug	ZG1/2"
35	CD6236-05-48	Cover	
36	GB1160.1-89	Oil Sight Glass	20
37	GB70-85	Socket Head Cap Screw	M6×35
38	CD6236-05-62	Plate	
39	GB1096-79	Key	8×28
40	CD6236-05-01	Shaft	

No.	Part No.	Name	Specification
41	HG4-692-67	Oil Seal	PD20×35×10
42	GB70-85	Socket Head Cap Screw	M6×16
43	CD6236-05-11	Bracket	
44	CD6236-05-64	Packing	
45	GB290-64	Roller Bearing	943/20
46	CD6236-05-12	Washer	
47	GB894.1-86	Circlip	20
48	CD6236-05-13	Gear	Mn=2.25 Z=39 Mn=1.75 Z=20
49	CD6236-05-14	Shaft	
50	GB1096-79	Key	5×8
51	GB276-84	Ball Bearing	7000104
52	CD6236-05-15	Gear	Mn=1.5 Z=38
53	CD6236-05-22	Gear	Mn=2. Z=23 Mn=1.5 Z=19
54	GB894.1-86	Circlip	20
55	CD6236-05-27	Washer	
56	GB893.1-86	Circlip	40
57	GB276-82	Ball Bearing	203
58	CD6236-05-28	Clutch	
59	CD6236-05-76	Washer	
60	GB894.1-86	Circlip	14
61	CD6236-05-29	Clutch Gear	
62	GB894.1-86	Circlip	20
63	CD6236-05-31	Washer	
64	CD6236-05-32	Packing	
65	CD6236-05-33	Cover	
66	GB70-85	Socket Head Cap Screw	M6×16
67	HG4-692-67	Oil Seal	PD20×35×10
68	CD6236-05-30	Shaft	
69	CD6236-05-40	Fork	
70	CD6236-05-88	Lever	
71	GB308-84	Steel Ball	φ6.5
72	GB2089-80	Spring	0.8×5×17
73	CD6236-05-90	Shaft	
74	GB1096-79	Key	4×12
75	CD6236-05-101	Sleeve	
76	GB3452.1-82	O-Ring	16×2.65
77	CD6236-05-63A	Lever	
78	CD6236-05-63	Lever	
79	CL6132-04-90	Plate	
80	GB77-85	Screw	M6×6

No.	Part No.	Name	Specification
81	GB879-86	Spring Pin	4×25
82	CD6236-05-100	Washer	
83	GB70-85	Socket Head Cap Screw	M5×12
84	GB276-84	Ball Bearing	7000104
85	CD6236-05-67	Shaft	
86	CD6236-05-66	Washer	
87	CD6236-05-68	Gear	Mn=1.75Z=30 Mn=2.25 Z=19
88	CD6236-05-69	Washer	
89	GB894.1-86	Circlip	25
90	GB276-84	Ball Bearing	7000104
91	CD6236-05-16	Gear	Mn=2 Z=22
92	CD6236-05-17	Gear	Mn=1.5 Z=19
93	CD6236-05-18	Gear	Mn=2. Z=20
94	CD6236-05-19	Gear	Mn=2 Z=24
95	CD6236-05-20	Gear	Mn=2 Z=23
96	CD6236-05-21	Gear	Mn=1.5 Z=27
97	CD6236-05-23	Gear	Mn=1.5 Z=24
98	CD6236-05-24	Gear	Mn=1.75 Z=28
99	CD6236-05-25	Gear	Mn=1.75 Z=26
100	CD6236-05-26	Gear	Mn=1.5 Z=38
101	CD6236-05-27	Washer	
102	GB276-82	Ball Bearing	203
103	CD6236-05-77	Nut	
104	CD6236-05-79	Gear	Mn=1.5 Z=33
105	CD6236-05-81	Bracket	
106	GB70-85	Socket Head Cap Screw	M6×16
107	GB1096-79	Key	5×35
108	GB893.1-86	Circlip	40
109	GB77-85	Screw	M5×8
110	GB894.1-86	Circlip	22
111	HG4-692-67	Oil Seal	PD25×40×10
112	GB301-84	Thrust Bearing	8105
113	CD6236-05-78	Shaft	
114	CD6236-05-41	Fork	
115	GB276-84	Ball Bearing	7000104
116	GB1096-79	Key	5×16
117	CD6236-05-71	Shaft	
118	CD6236-05-70	Gear	Mn=2.25 Z=22
119	GB894.1-86	Circlip	20
120	CD6236-05-72	Gear	Mn=2 Z=22

No.	Part No.	Name	Specification
121	CD6236-05-73	Gear	Mn=2 Z=22
122	CD6236-05-74	Gear	Mn=1.5 Z=33
123	CD6236-05-75	Gear	Mn=1.75 Z=22
124	CD6236-05-27	Washer	
125	CD6236-05-80	Gear	Mn=1.25Z=36 Mn=1.25 Z=20
126	GB276-86	Roller Bearing	101
127	CD6236-05-99	Packing	
128	CD6236-05-82	Bracket	
129	GB70-85	Socket Head Cap Screw	M6×16
130	CD6236-05-35	Lever	
131	GB1096-79	Key	4×12
132	CD6236-05-38-1	Shaft	
133	CD6236-05-84	Lever	
134	CD6236-05-43	Fork	
135	CD6236-05-39	Fork	
136	GB93-87	Spring Washer	6
137	GB70-85	Socket Head Cap Screw	M6×16
138	CD6236-05-83	Washer	
139	GB894.1-86	Circlip	17
140	GB77-85	Screw	M8×8
141	GB2089-80	Spring	0.8×5×17
142	GB308-84	Steel Ball	φ6.5
143	CD6236-05-36	Cam	
144	CD6236-05-86	Fork	
145	CD6236-05-38	Shaft	
146	CD6236-05-98	Fork	
147	CD6236-05-85	Lever	
148	GB879-86	Spring Pin	3×4
149	CD6236-05-37	Bracket	
150	GB879-86	Spring Pin	5×18
151	GB896-86	Circlip	8
152	GB3452.1-82	O-Ring	38.7×2.65
153	CD6236-05-50	Bracket	
154	GB3452.1-82	O-Ring	30×2.65
155	CD6236-05-49	Cover	
156	GB70-85	Socket Head Cap Screw	M5×25
157	CD6236-05-46	Selector	
158	GB2089-80	Spring	1×8×32
159	CD6236-05-44/01	Lever	
160	CD6236-05-44/02	Lever	

20. Apron

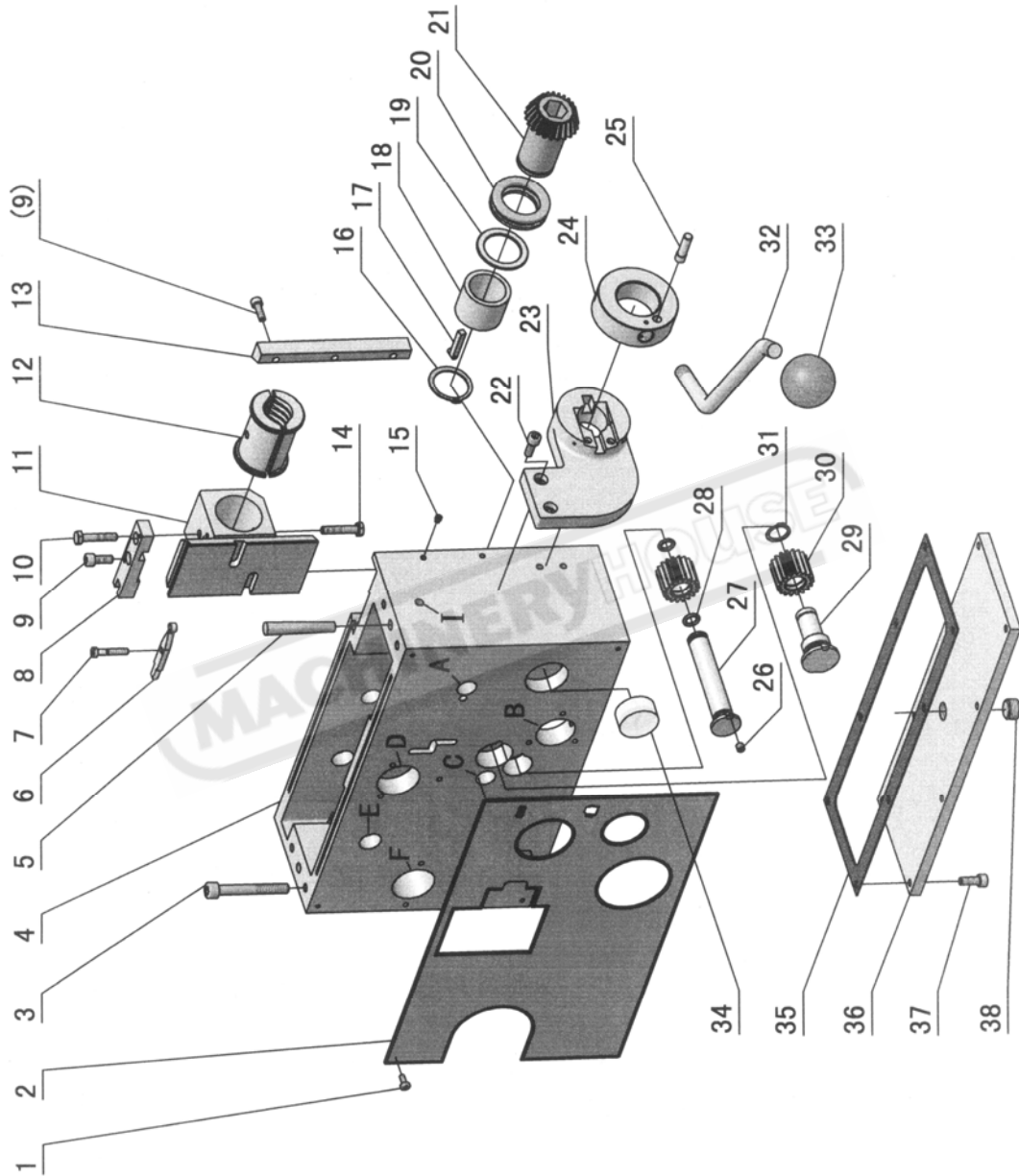

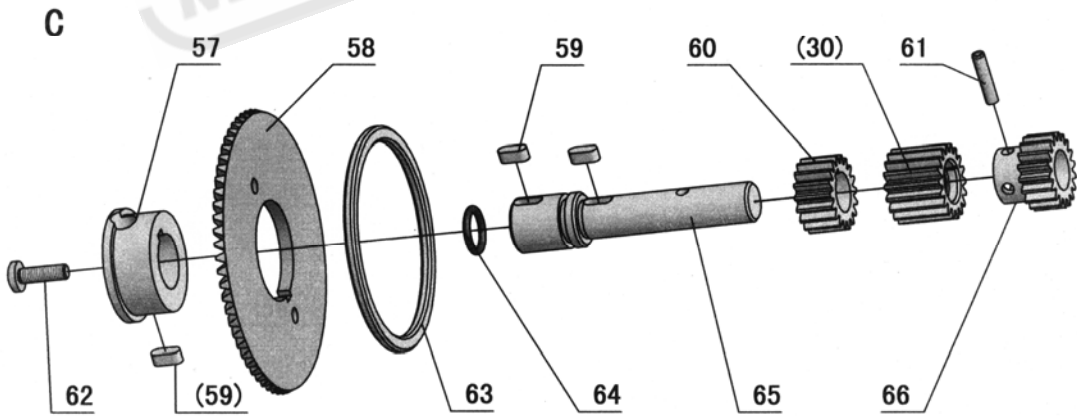
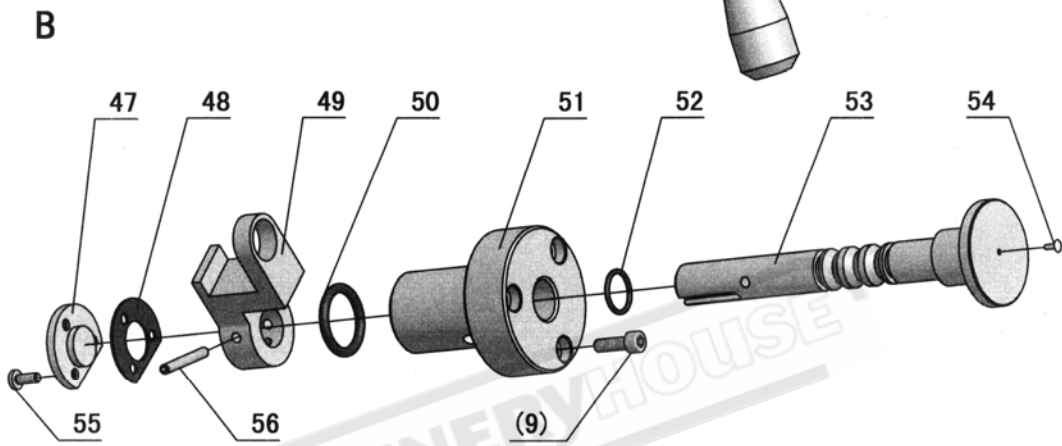
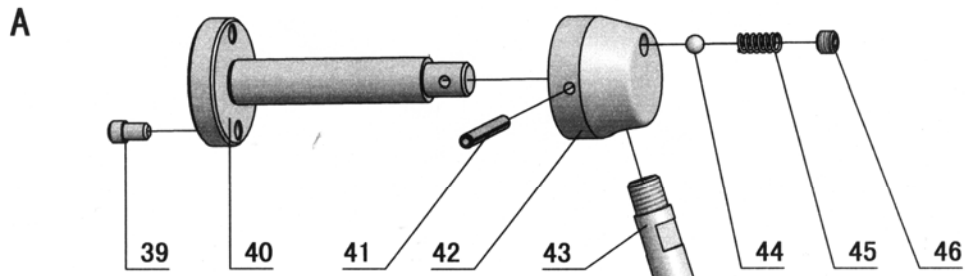

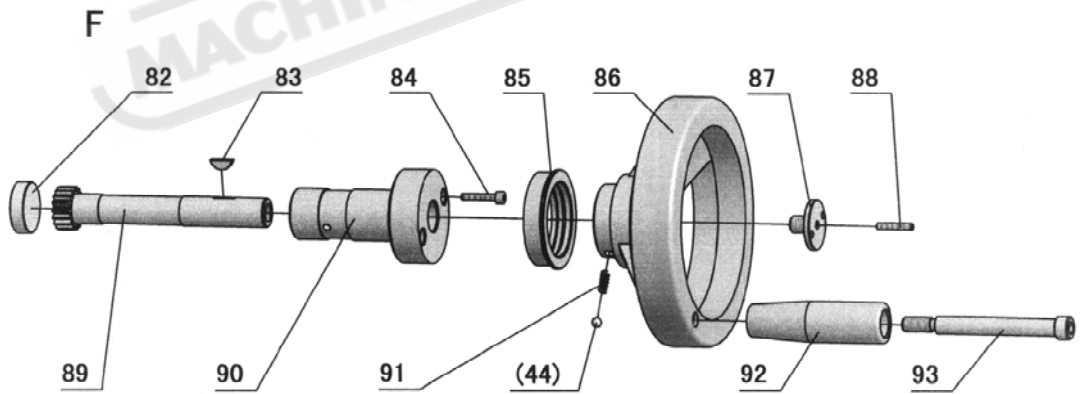
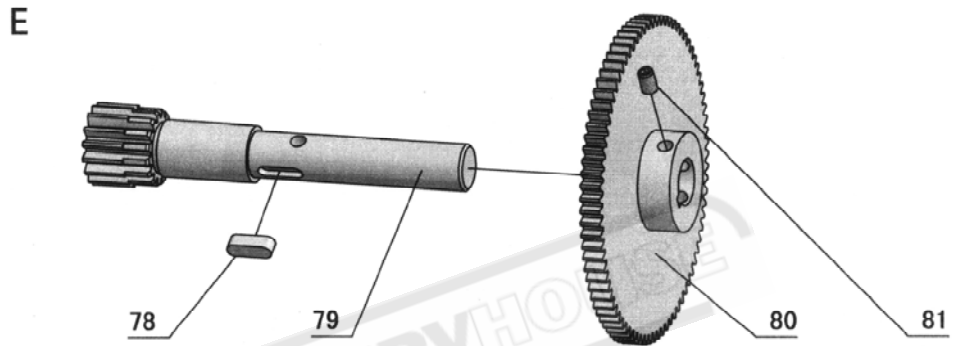
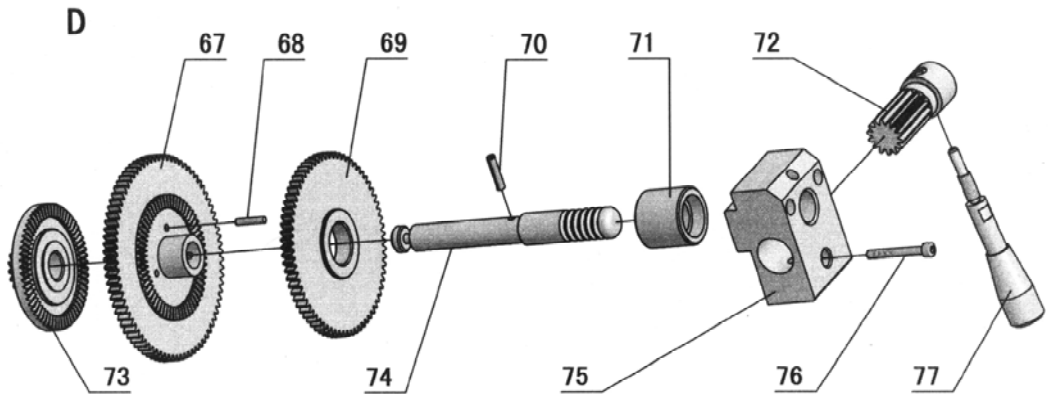

I

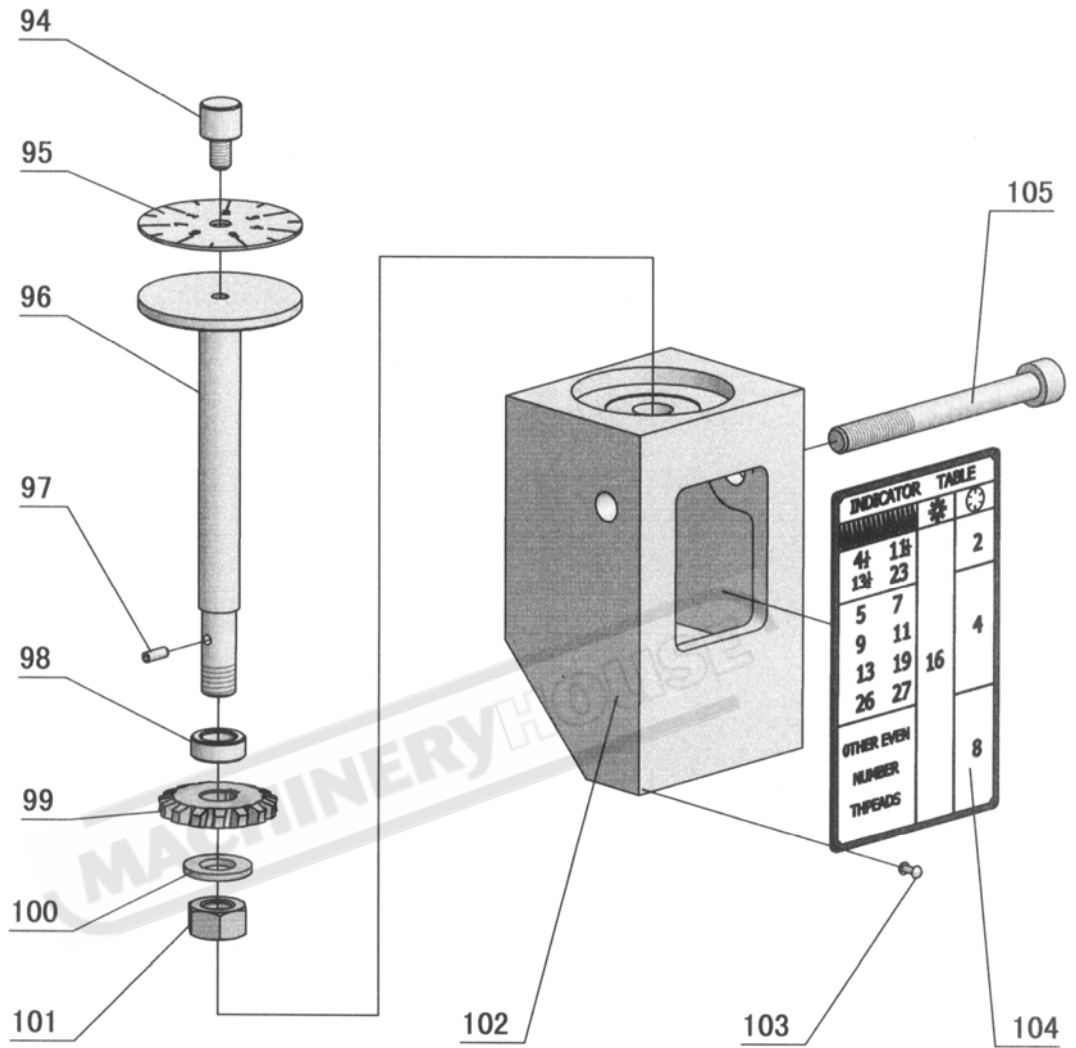

No.	Part No.	Name	Specification
1	GB818-85	Screw	M4×10
2	CD6236-06-03	Name Plate	
3	GB70-85	Socket Head Cap Screw	M8×60
4	CD6236-06-01	Apron Casting	
5	GB117-86	Pin	B8×60
6	CD6236-06-31	Lever	
7	CD6236-06-51	Bolt	
8	CD6236-06-39	Stopper	
9	GB70-85	Socket Head Cap Screw	M5×16
10	GB5782-86	Bolt	M6×12
11	CD6236-06-38	Half Bracket	
12	CD6236-06-52	Half Nut(Inch)	4TPI
13	CD6236-06-30	Gib	
14	GB5782-86	Bolt	M6×10
15	GB79-85	Socket Head Set Screw	M5×6
16	GB894.1-86	Clip	30
17	CD6236-06-35	Key	
18	GB290-82	Needle Bearing	7943/30
19	CD6236-06-28	Washer	
20	GB301-84	Thrust Bearing	8106
21	CD6236-06-29	Gear-Drive Level	Mn=1.75 Z=23
22	GB70-85	Socket Head Cap Screw	M6×16
23	RUN6246-106059	Switch Brackek	
24	RUN6246-106053	Bracket	
25	RUN6246-106055	Pin	
26	GB77-85	Socket Head Set Screw	M6×6
27	CD6236-06-44	Shaft	
28	GB3452.1-82	O-Ring	11.2×2.65
29	CD6236-06-19	Shaft	
30	CD6236-06-50	Gear	Mn=1.5 Z=18
31	GB894.1-86	External Circle	16
32	CD6236-06-33	Spindle Control Lever	
33	Z16-1	Lever Bush	
34	GB1160-86	Sight Glass	B20
35	CD6236-06-49	Packing	
36	CD6236-06-48	Bottom Plate	
37	GB70-85	Socket Head Cap Screw	M5×16
38	Q/ZB285.3	Oil Plug	R 3/8"
39	CD6236-06-37	Pin	
40	CD6236-06-25	Shaft	

No.	Part No.	Name	Specification
41	GB879-86	Spring Pin	5×42
42	CD6236-06-26	Lever Head	
43	CD6236-06-27	Handle	
44	GB308-84	Steel Ball	φ6.5
45	GB896-86	Clip	8
46	GB77-85	Socket Head Cap Screw	M8×6
47	CD6236-06-43	Cover	
48	CD6236-06-42	Packing	
49	CD6236-06-41	Fork	
50	GB3452.1-82	O-Ring	25.8×3.55
51	CD6236-06-22	Sleeve	
52	GB3452.1-82	O-Ring	16×1.8
53	CD6236-06-21	Shaft	
54	GB827-86	Rivet	2×6
55	GB818-85	Screw	M4×10
56	GB879-86	Spring Pin	4×30
57	CD6236-06-18-02	Input Bush	
58	CD6236-06-45	Gear-Drive Bevel	Mn=1.75 Z=64
59	GB1096-79	Key	5×12
60	CD6236-06-47	Gear	Mn=1.5 Z=18
61	GB879-86	Spring Pin	5×22
62	GB818-85	Screw	M6×20
63	CD6236-06-46	Washer	
64	GB3452.1-82	O-Ring	11.2×2.65
65	CD6236-06-18-01	Shaft	
66	CD6236-06-17	Gear	Mn=1.5 Z=18
67	CD6236-06-11	Gear	Mn=1.5Z=80 Mn=1.25 Z=60
68	GB119-86	Pin	D4×20
69	CD6236-06-12	Gear	Mn=1.5Z=72 Mn=1.25 Z=60
70	GB879-86	Spring Pin	5×22
71	CD6236-06-15	Sleeve	
72	CD6236-06-40	Gear Shaft	Mn=1.5 Z=14
73	CD6236-06-34	Gear	Mn=1.5Z=18 Mn=1.25 Z=60
74	CD6236-06-13	Shaft	
75	CD6236-06-14	Lever Head	
76	GB70-85	Socket Head Cap Screw	M5×40
77	CD6236-06-16	Lever	
78	GB1096-79	Key	6×18
79	CD6236-06-10	Shaft	Mn=1.75 Z=16
80	CD6236-06-09	Gear	Mn=1.5 Z=81

No.	Part No.	Name	Specification
81	GB78-85	Screw	M6×10
82	CD6236-06-23	Plug	
83	GB1099-79	Wood ruff Key	5×6.5×16
84	GB70-85	Socket Head Cap Screw	M5×25
85	CD6236-06-08	Dial	
86	CD6236-06-07	Hand Wheel	
87	CD6236-08-16	Screw Plug	
88	GB79-85	Set Screw	M5×25
89	CD6236-06-02	Shaft	
90	CD6236-06-04	Sleeve	
91	GB2089-80	Spring	
92	CD6236-06-05	Handle	
93	CD6236-06-06	Bolt	
94	CD6236-06-32 1/9	Screw	
95	CD6236-06-32-3G	Plate	
96	CD6236-06-32-1G	Shaft	
97	GB879-86	Spring Pin	3×8
98	CD6236-06-32-2G	Washer	
99	CD6236-06-32 2/5G	Worm Gear	Mn=2 Z=14
100	GB93-86	Spring Washer	10
101	GB6170-86	Nut	M10
102	CD6236-06-32G	Worm Unit	
103	GB827-86	Rivet	2×5
104	CD6236-06-32 5/5G	Plate	

21. Saddle

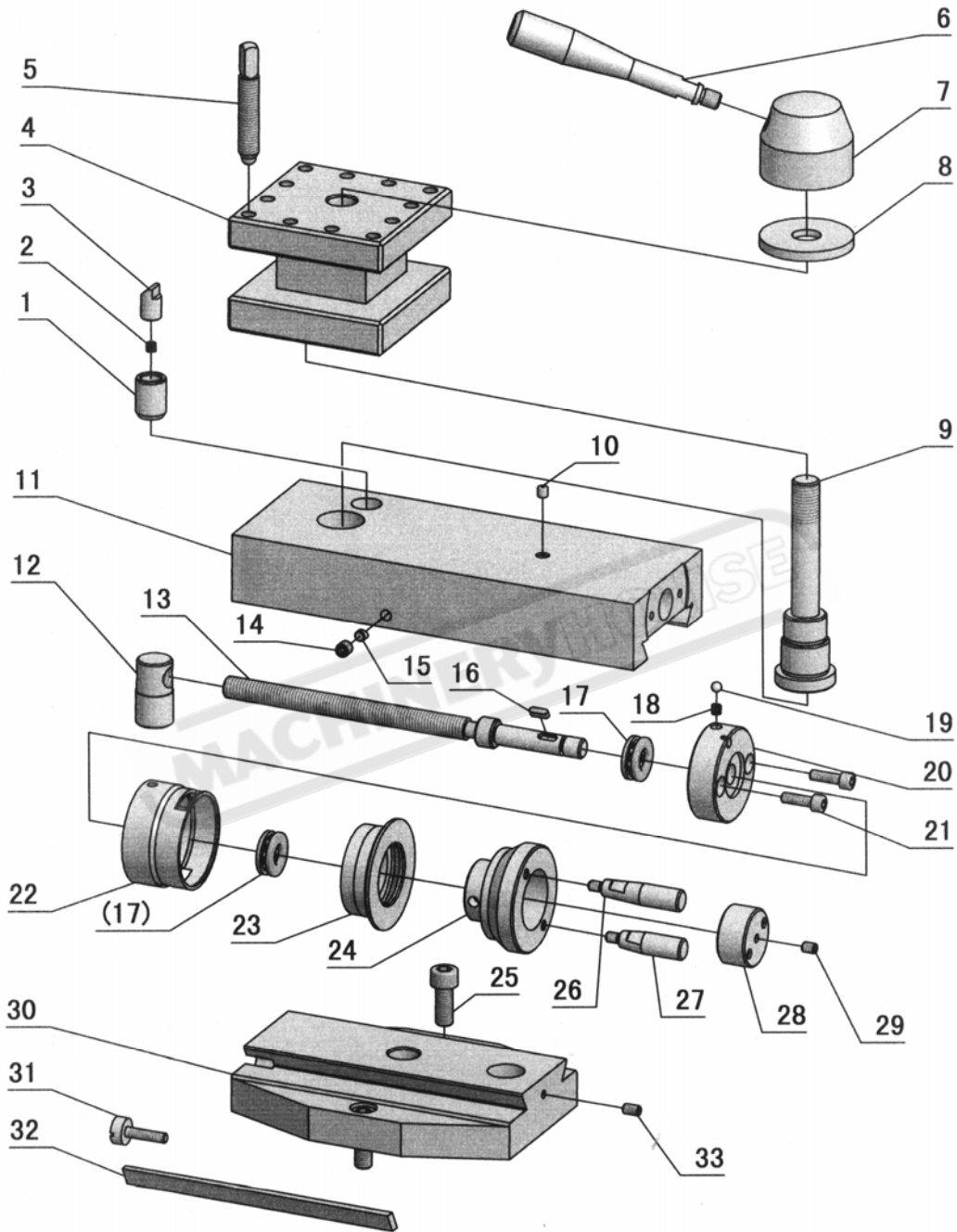

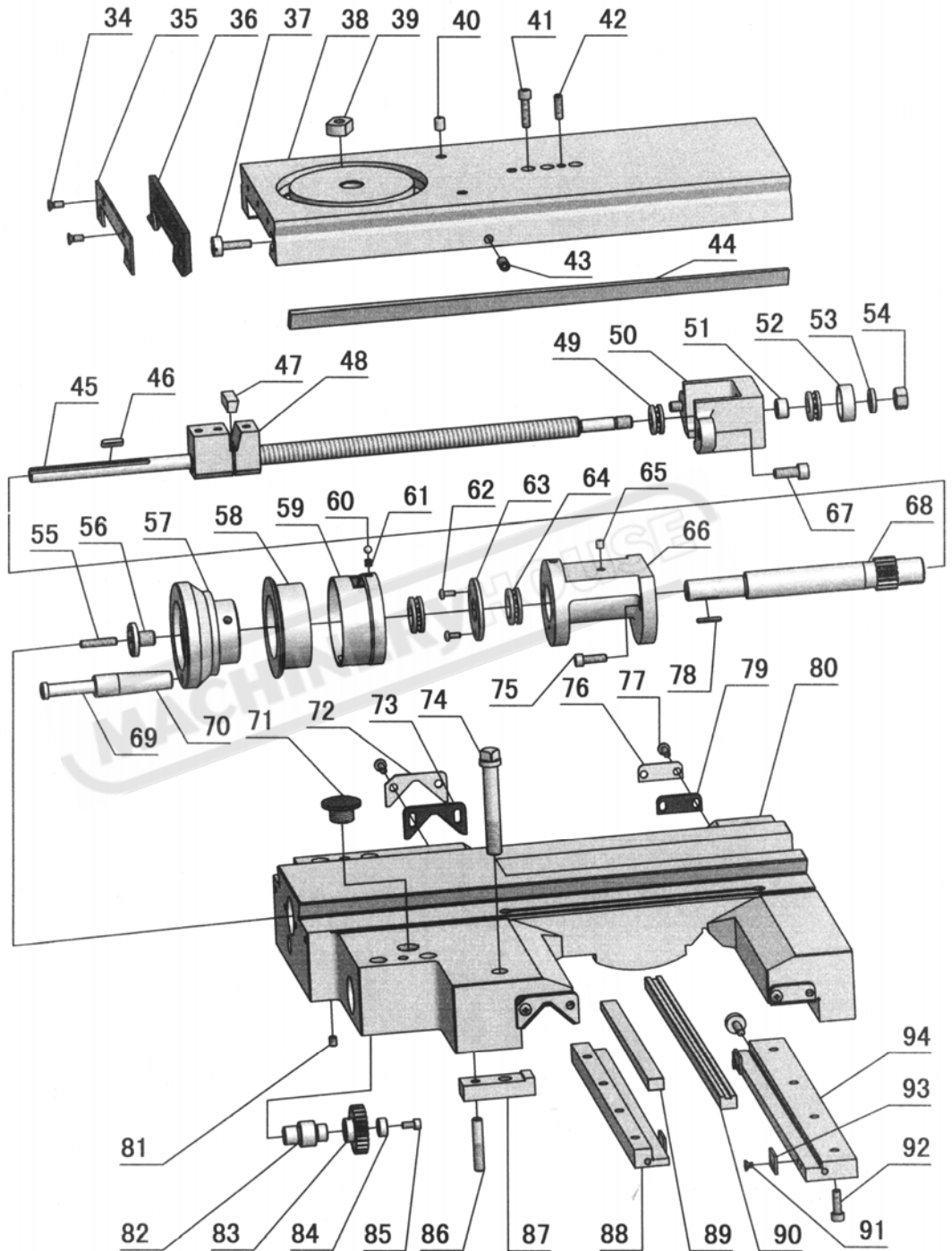

No.	Part No.	Name	Specification
1	CD6236-07-49A	Bush(S-Post)	
1	CD6236-07-49	Bush(T-Post)	
2	GB2089-80	Spring	0.5×5×18
3	CD6236-07-50	Pin	
4	CD6236-07-21	Tool Post	
5	GB98-83	Screw	M10×50
6	CD6236-07-29	Clamp Handle	
7	CD6236-07-19	Clamping Handle	
8	CD6236-07-20	Washer	
9	CD6236-07-18A	Tool Post Shaft(S-Post)	
9	CD6236-07-18	Tool Post Shaft(T-Post)	
10	GB1155-79	Ball Cup	6
11	CD6236-07-25A	Compound Rest(360S-Post)	
11	CD6240-07-25A	Compound Rest(410S-Post)	
11	CD6236-07-25	Compound Rest(360T-Post)	
11	CD6240-07-25	Compound Rest(410T-Post)	
12	CD6236-07-17G	Nut(Metric)	
12	CD6236-07-17	Nut(Inch)	
13	CD6236-07-07G	Feed Screw(Metric)	
13	CD6236-07-07	Feed Screw(Inch)	
14	GB77-85	Screw	M8×8
15	CD6236-07-46	Bottom	
16	GB1096-79	Key	4×12
17	GB301-84	Thrust Bearing	8101
18	GB2089-80	Spring	0.5×5×18
19	GB308-77	Steel Ball	6
20	CD6236-07-13	Seat	
21	GB70-85	Screw	M6×20
22	CD6236-07-12G	Steel Ball(Metric)	
22	CD6236-07-12	Steel Ball(Inch)	
23	CD6236-07-11G	Dial-Compound Rest(M)	
23	CD6236-07-11	Dial-Compound Rest(Inch)	
24	CD6236-07-10	Handle	
25	GB70-85	Screw	M10×25
26	CD6236-07-05	Handle	
27	CD6236-07-06	Handle	
28	CD6236-07-08	Screw Plug	
29	GB77-85	Screw	M6×8
30	CD6236-07-26	Swivel Table(360)	
30	CD6240-07-26	Swivel Table(410)	

No.	Part No.	Name	Specification
31	CD6236-07-48	Screw	
32	CD6236-07-47	Gib	
33	GB77-85	Screw	M6×10
34	GB819-85	Screw	M5×12
35	CD6236-07-44	Wiper Cover	
36	CD6236-07-45	Wiper	
37	CD6236-07-48	Screw	
38	CD6236-07-27	Cover-Cross Sliding	
39	CD6236-07-64	T-Bracket	
40	GB1155-79	Ball Cup	8
41	GB70-85	Screw	M6×25
42	GB77-85	Screw	M6×20
43	GB77-85	Screw	M8×16
44	CD6236-07-23	Gib	
45	CD6236-07-55G	Feed Screw(Metric)	
45	CD6236-07-55	Feed Screw(Inch)	
46	CD6240-07-63a-2	Key	4×18
47	RUN6246-103004	Bracket	
48	CD6236-07-51Ga	Nut(Metric)	
48	CD6236-07-51a	Nut(Inch)	
49	GB301-84	Thrust Bearing	8100
50	CD6236-07-22	Bracket	
51	CD6236-07-14	Spacer	
52	CD6236-07-30	Bearing Cover	
53	CD6236-07-09	Bracket	
54	GB6175-86	Clamping Nut	M10
55	GB77-85	Screw	M6×35
56	CD6236-07-37	Clamping Screw	
57	CD6236-07-38	Wheel;	
58	CD6236-07-41G	Dial-Feed(Metric)	
58	CD6236-07-41	Dial-Feed(Inch)	
59	CD6236-07-42G	Handle Spacer(Metric)	
59	CD6236-07-42	Handle Spacer(Inch)	
60	GB308-77	Steel Ball	6
61	GB2089-80	Spring	0.5×5×18
62	GB818-85	Screw	M4×10
63	CD6236-07-43	Washer	
64	GB301-84	Thrust Bearing	8103
65	GB1155-79	Ball Cup	6
66	CD6236-07-36	Bracket	

No.	Part No.	Name	Specification
67	GB77-85	Screw	M8×20
68	CD6240-07-63a	Gear Shaft	Mn=1.5 Z=16
69	CD6236-07-40	Screw	
70	CD6236-07-39	Handle Spacer	
71	CD6236-07-15	Plug	
72	CD6236-07-34	Wiper Cover	
73	CD6236-07-33	Wiper	
74	CD6236-07-04	Clamp Screw	
75	GB70-85	Screw	M6×20
76	CD6236-07-32	Wiper Cover	
77	GB818-85	Screw	M5×16
78	GB1096-86	Key	3×3×20
79	CD6236-07-31	Wiper	
80	CD6236-07-28	Carriage	
81	GB77-85	Screw	M6×8
82	CD6236-07-61	Shaft	
83	CD6236-07-60	Gear	Mn=1.5 Z=25
84	CD6236-07-59	Washer	
85	GB70-85	Screw	M5×10
86	CD6236-07-03	Support Screw	
87	CD6236-07-02	Clamp Block	
88	CD6236-07-16	Gib	
89	CD6236-07-58	Gib	
90	CD6236-07-57	Gib	
91	GB68-85	Screw	M4×6
92	GB70-85	Screw	M6×20
93	CD6236-07-16-1	Baffle	
94	CD6236-07-56	Gib	

22. Lubrication

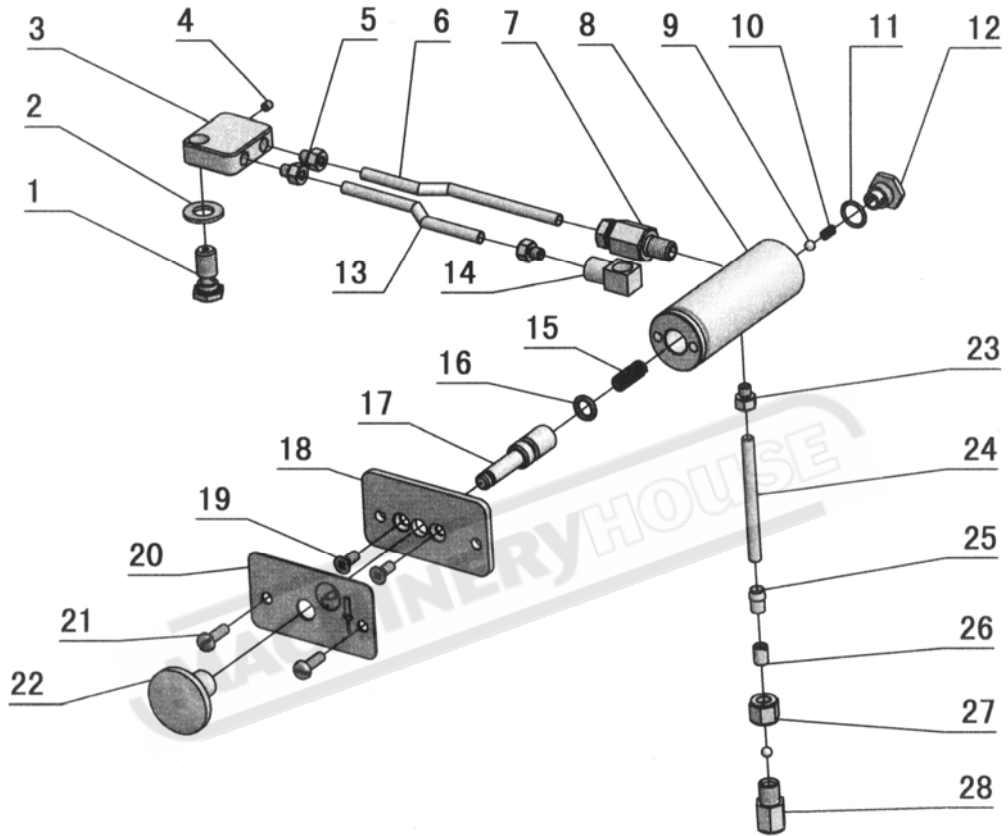

No.	Part No.	Name	Specification
1	CD6236-07-01 13/13	Proper Screw	
2	GB97.1-85	Washer	10
3	CD6236-07-01 10/13	Distributor	
4	GB77-85	Screw	M4×5
5	15326C	Tie-in	
6		Lubrication Tube	φ5
7	2143SC	Tie-in	φ5/Z1/8
8	CD6236-07-01 6/13a	Pump	
9	GB308-77	Ball	5
10	GB2089-80	Spring	0.5×4×15
11	GB3452.1-82	O-Ring	11.2×1.8
12	CD6236-07-01 5/13	Plug	
13		Lubrication Tube	φ5
14	CD6236-07-01 7/13	Joint	
15	GB2089-80	Spring	1×7×45
16	GB3452.1-82	O-Ring	8×2.65
17	CD6236-07-01 2/13	Piston	
18	CD6236-07-01 4/13	Plate	
19	GB819-85	Screw	M5×12
20	CD6236-07-01 3/13	Name Plate	
21	GB67-85	Screw	M5×15
22	RUN6241-103067	Knob	
23	22587T	Tie-in	φ6/Z1/8
24		Lubrication Tube	φ6×150
25	RUN6246-103071	Tie-in	
26	RUN6246-103072	Nut	
27	B1061C	Double Taper Sheath	4
28	RUN6246-103073	Valve	

23. Tailstock Assembly

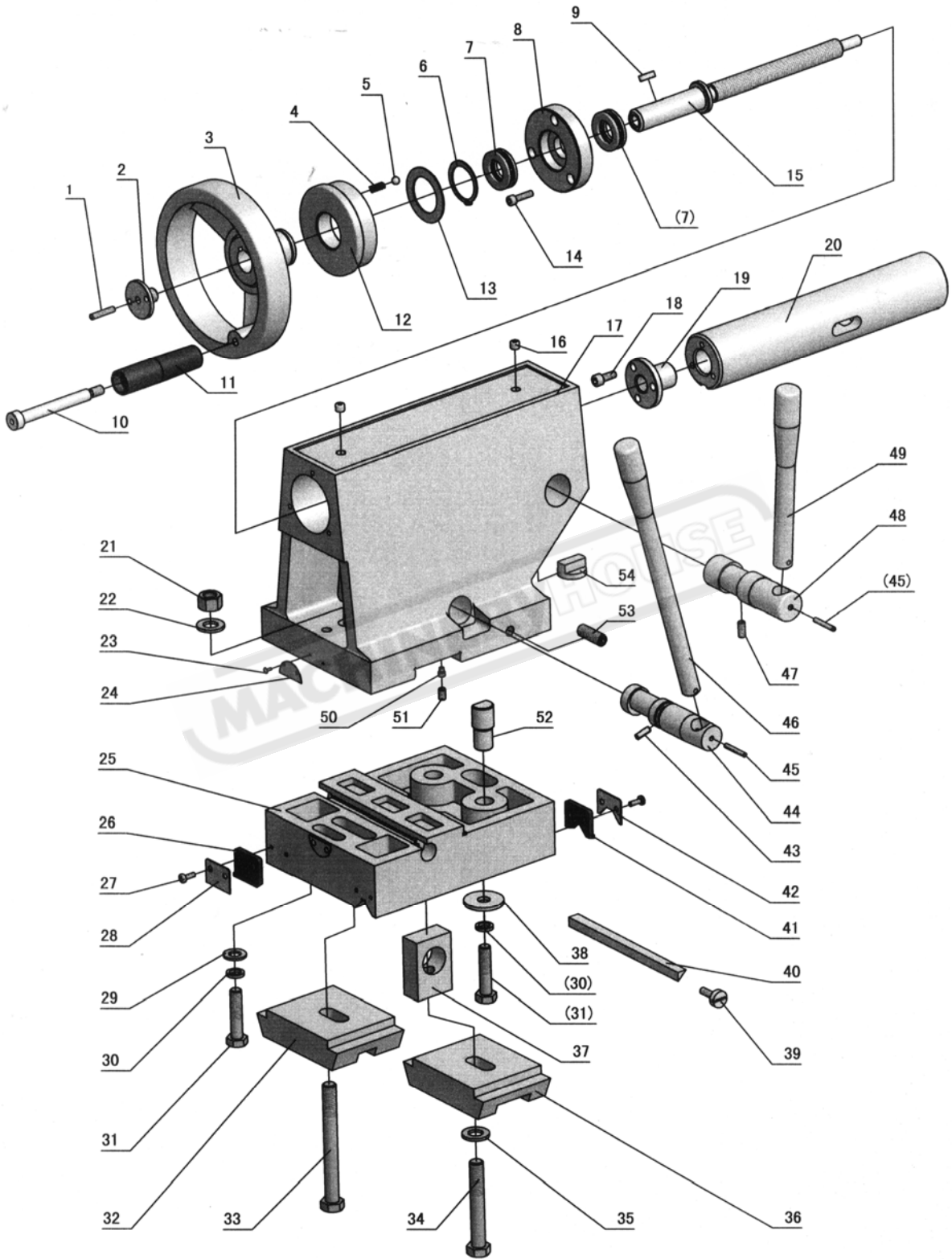

No.	Part No.	Name	Specification
1	GB78-85	Key	5×25
2	CD6236-08-16	Screw Plug	
3	CD6236-08-17	Hand Wheel	
4	GB2089-80	Spring	0.6×5×16
5	GB308-84	Steel Ball	Φ6.5
6	GB894.1-86	Retaining Ring	32
7	GB301-84	Thrust Bearing	8104
8	CD6236-08-13	Bracket	
9	GB1096-79	Key	5×16
10	CD6236-08-18	Bolt	
11	CD6236-08-19	Handle	
12	CD6236-08-14	Dial	
13	CD6236-08-15	Retaining Ring	
14	GB70-85	Screw	M5×25
15	CD6236-08-11	Feed Screw	
16	GB1155-79	Oil Cup	8
17	CD6236-08-01	Tailstock	
18	GB70-85	Screw	M6×16
19	CD6236-08-12	Feed Nut	
20	CD6236-08-10	Quill	
21	GB55-76	Hexagon Thick Nut	M12
22	GB97-85	Washer	12
23	GB827-85	Button Head Rivet	2×8
24	CD6236-08-26	Set-Over Indication Chart	
25	CD6236-08-05	Tail Stock Base	
26	CD6236-08-25	Bedway Wiper	
27	GB818-85	Cross Screw	M4×10
28	CD6236-08-27	Bedway Wiper Plate	
29	GB97.1-86	Washer	10
30	GB93-85	Spring Washer	10
31	GB5780-86	Bolt	M10×45
32	CD6236-08-29	Clamping Block	
33	GB5780-86	Bolt	M12×110
34	GB5780-86	Bolt	M12×80
35	GB95-86	Washer	12
36	CD6236-08-06	Clamping Block	
37	CD6236-08-20	Adjusting Block	
38	CD6236-08-30	Washer	
39	CD6236-08-04	Screw	
40	CD6236-08-03	Gib	

No.	Part No.	Name	Specification
41	CD6236-08-02	Bedway Wiper	
42	CD6236-08-28	Bedway Wiper Plate	
43	GB879-86	Spring Pin	5×15
44	CD6236-08-21	socket wrench	
45	GB879-86	Spring Pin	4×25
46	CD6236-08-22	Clamping Lever	
47	GB77-85	Socket Head Set Screw	M6×15
48	CD6236-08-23	Clamping Shaft	
49	CD6236-08-24	Clamping Lever	
50	GB79-85	Socket Head Set Screw	M6×10
51	GB77-85	Socket Head Set Screw	M6×10
52	CD6236-08-07	Shaft	
53	GB77-85	Socket Head Set Screw	M10×35
54	CD6236-08-09	Key	

MACHINERYHOUSE

24. Chuck Guard Cover

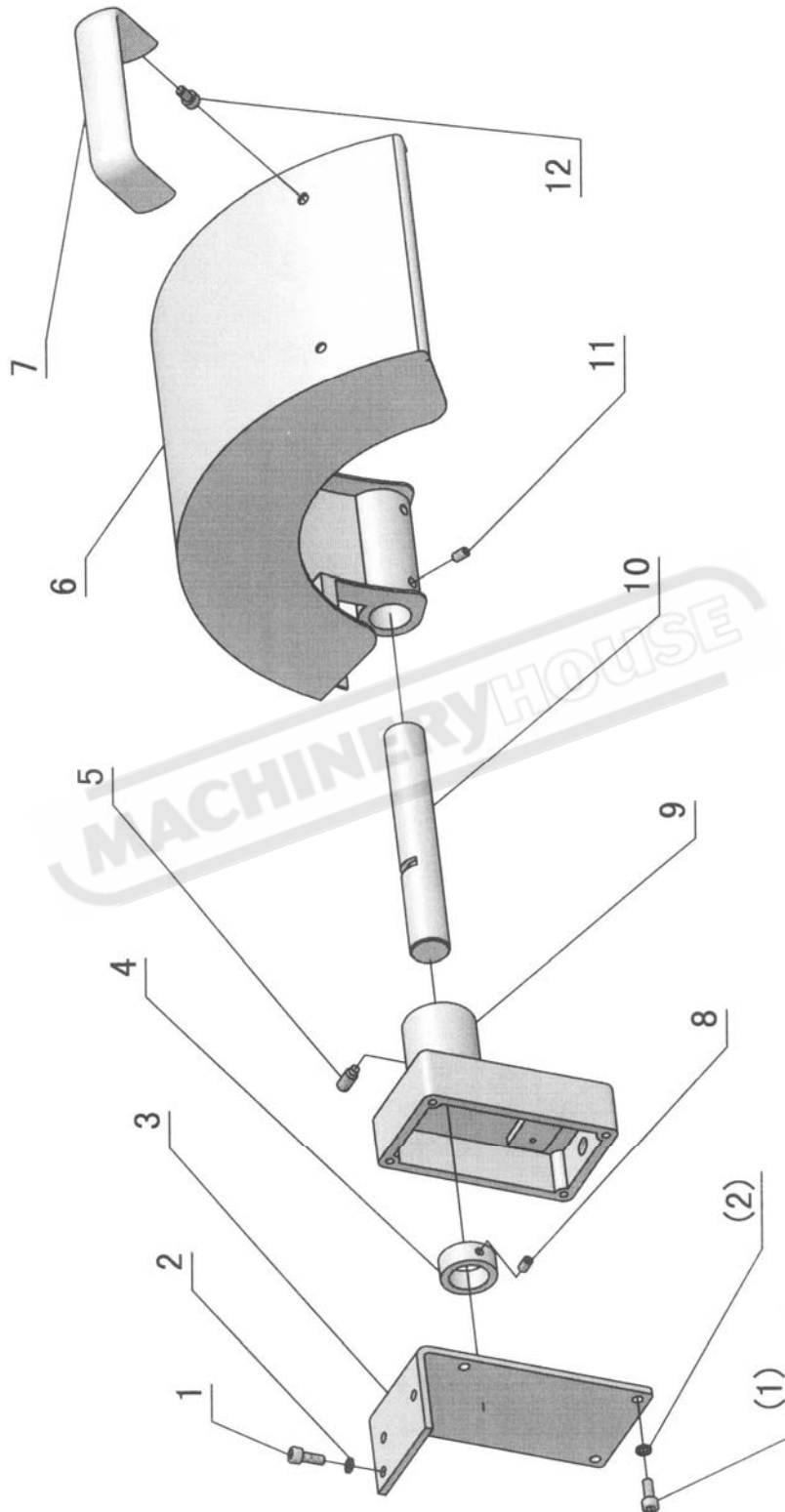

No.	Part No.	Name	Specification
1	GB70-85	Screw	M6×12
2	GB93-86	Washer	6
3	CD6236-04F-02	Support Bracket	
4	CM6233-F1005	Sleeve	
5	GB75-85	Screw	M8X20
6	CD6236-04FA-01	Cover	
7	HY8315.4 A=114	handle	
8	GB78-85	Screw	M6×10
9	RIN6236-101101	Cover Bracket	
10	CD6236-04FA-04	Shaft	
11	GB78-85	Screw	M8×10
12	GB70-85	Screw	M6×10

MACHINERYHOUSE

25. Follow Rest

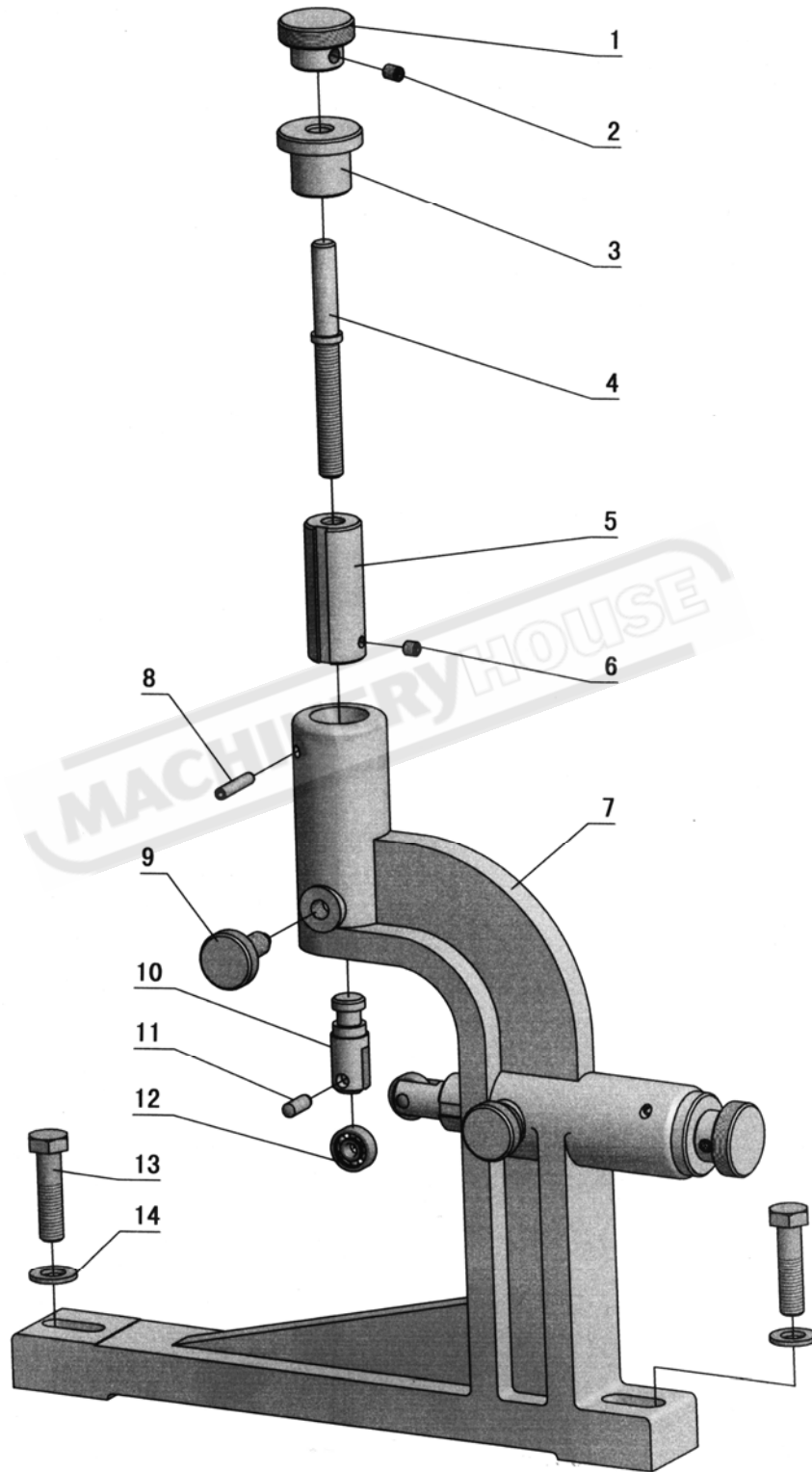

No.	Part No.	Name	Specification
1	RUN6246-110019	Rotate Handle	
2	GB78-85	Screw	M6×8
3	RUN6246-110004	Bush	
4	CD6236-10-11	Screw Shaft	
5	CD6236-10-10	Sleeve	
6	GB77-85	Screw	M6×6
7	CD6236-10-09	Follow Rest	
8	GB879-86	Spring Pin	5×26
9	RUN6246-110018	Limited Screw	
10	CD6236-10-08	Support Shaft	
11	GB119-86	Pin	6×16
12	GB278-88	Bearing	80026
13	GB5782-86	Bolt	M10×40
14	GB97.1-86	Washer	6×16

MACHINERYHOUSE

26. Steady Rest

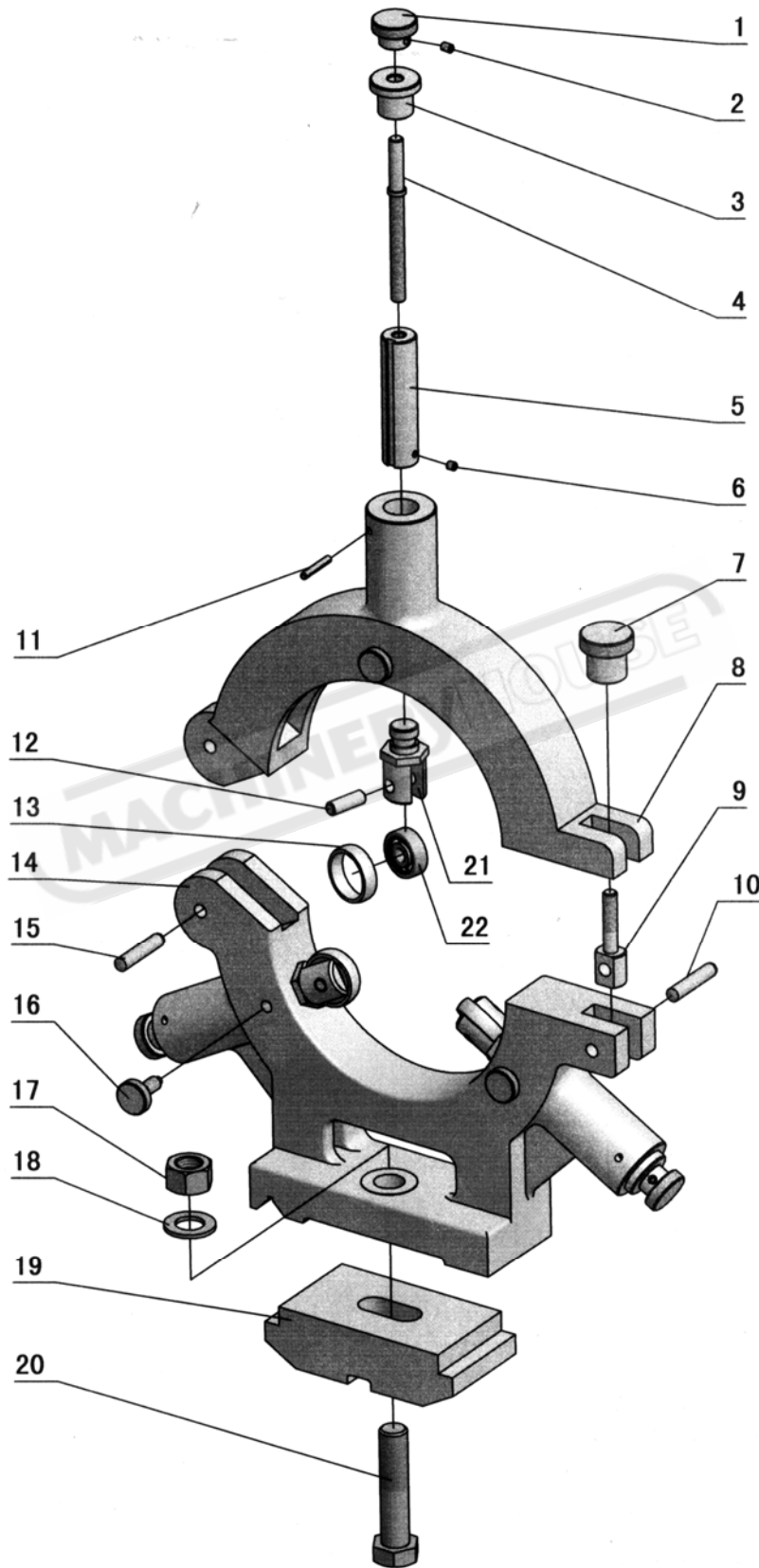

No.	Part No.	Name	Specification
1	RUN6246-110019	Rotate Handle	
2	GB78-85	Screw	M6×8
3	RUN6246-110004	Bush	
4	CD6240-10-05	Screw Shaft	
5	CD6236-10-04	Sleeve	
6	GB77-85	Screw	M6×6
7	RUN6246-110014	Handle	
8	CD6236-10-02	Upside of Steady Rest	
9	RUN6246-110013	Clamping Screw	
10	GB119-86	Pin	10×50
11	GB879-86	Spring Pin	5×32
12	GB119-86	Pin	6×20
13	CD6240-10-07	Guard Bush	
14	CD6236-10-01	Downside of Steady Rest	
15	GB119-86	Pin	10×50
16	RUN6246-110018	Limited Screw	
17	GB6170-86	Nut	M16
18	GB97.1-86	Washer	16
19	CD6240-10-03	Clamping Bracket	
20	GB5780-86	Bolt	M16×80
21	CD6236-10-06	Support Shaft	
22	GB278-88	Bearing	80026

27. Lead Screw Guard

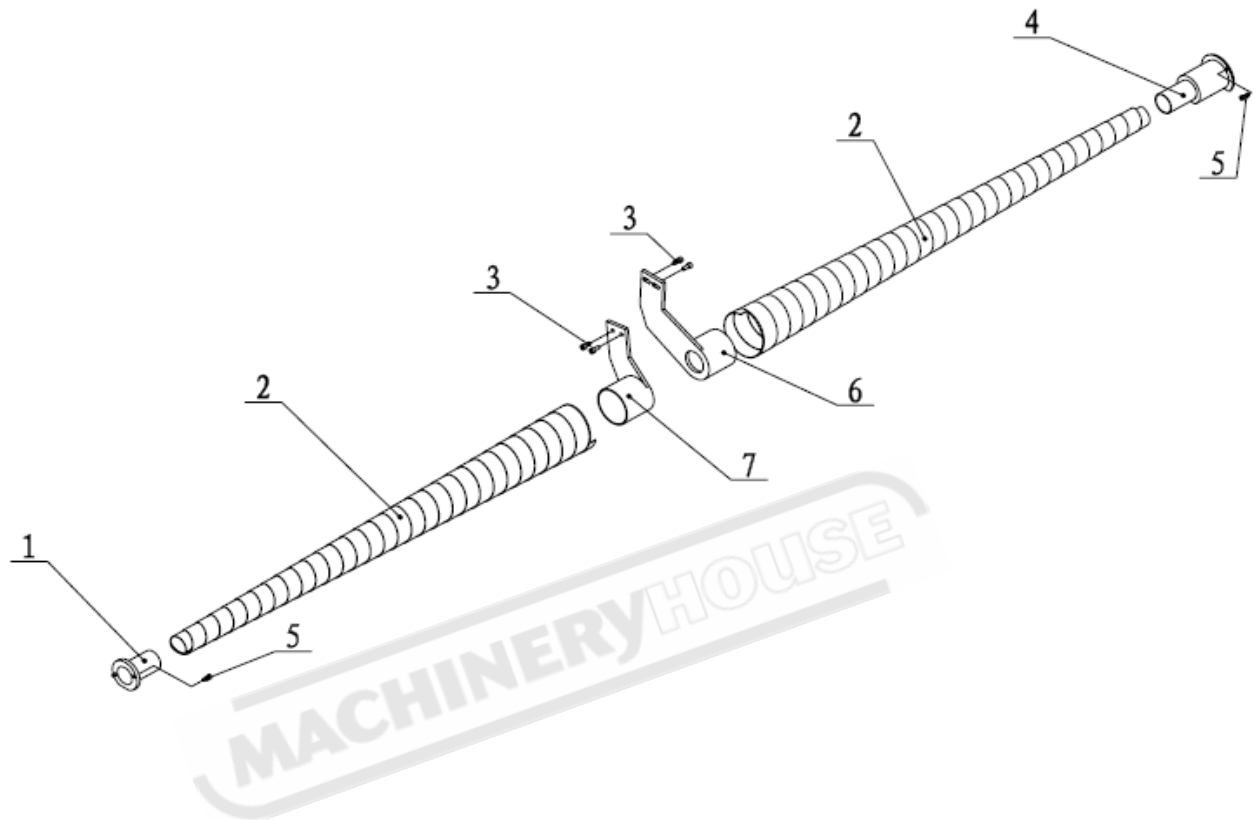

No.	Part No.	Name	Specification	Qty
1	CD6236-01F-05	Connect Sleeve		1
2	CD6236-01F-01	Protect Sleeve	1000	2
3	GB70-85	Socket Cap Screw	M5×12	4
4	CD6236-01F-02	Protect Sleeve	2000	2
5	GB70-85	Socket Cap Screw	M4×12	4
6	CD6236-01F-03	Connect Sleeve	1000、1500	1
7	CD6236-01F-04	Connect Sleeve	2000	1

28. Chip Protection

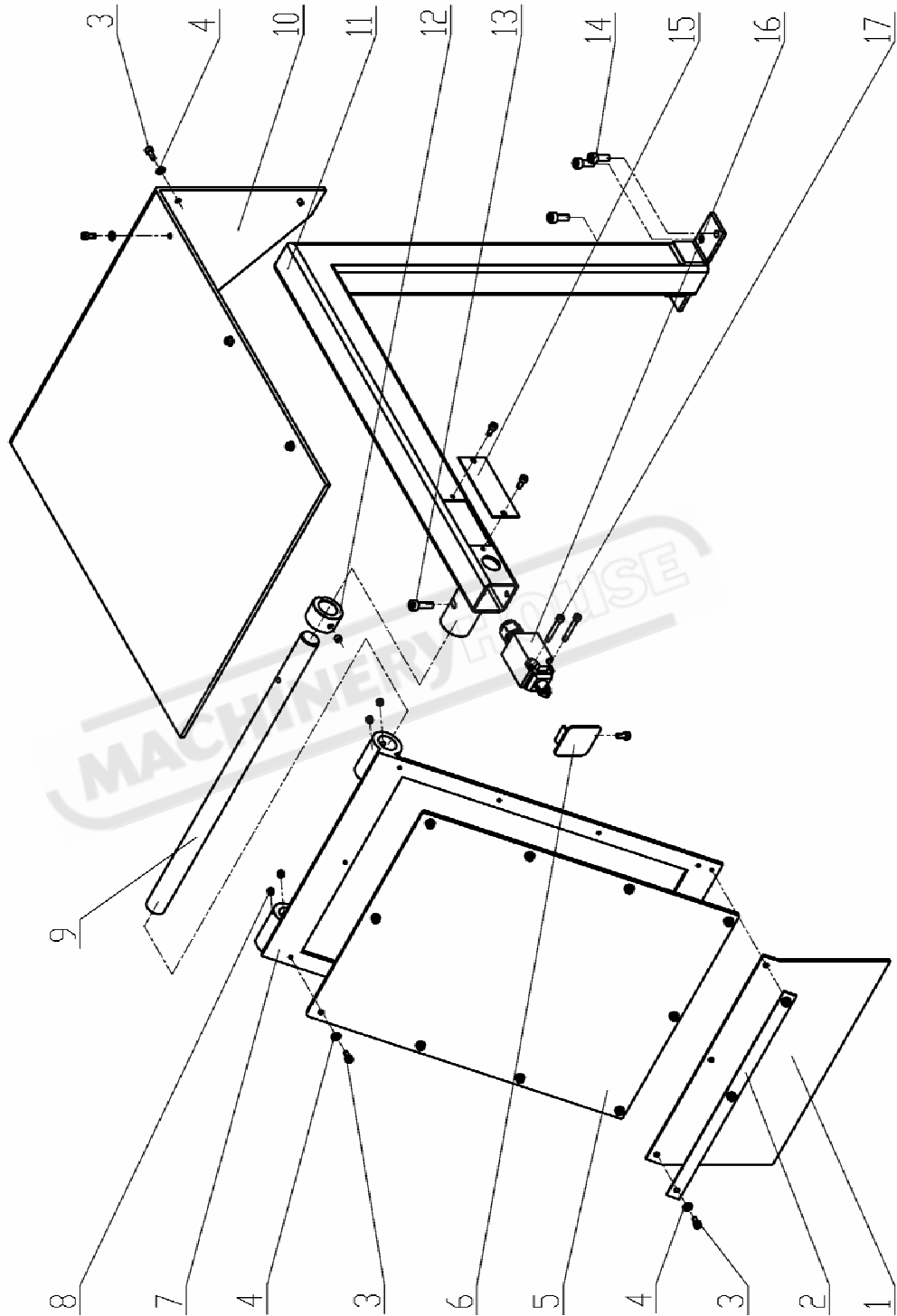

No.	Part No.	Name	Specification	Qty
1	CD6240-20-02	Chip Cover		1
2	CD6240-20-09	Clamp		1
3	GB70-85	Screw	M4×10	21
4	GB97.1-85	Washer	4	18
5	CD6240-20-07	Chip Cover		1
6	CD6240-20-03	Chip Cover Plate		1
7	CD6240-20-06	Chip Cover Fixing Plate		1
8	GB80-85	Screw	M6×6	5
9	CD6240-20-05	Shaft		1
10	CD6240-20-03	Top Cover Plate	Select Purchase	1
11	CD6240-20-01	Main Block		1
12	CD6240-20-04	Lock for Switch Stop		1
13	GB70-85	Screw	M6×20	1
14	GB70-85	Screw	M6×16	3
15	CD6240-20-02	Chip Cover Plate		1
16		Switch		1
17	GB70-85	Screw	M4×30	2

MACHINERYHOUSE